

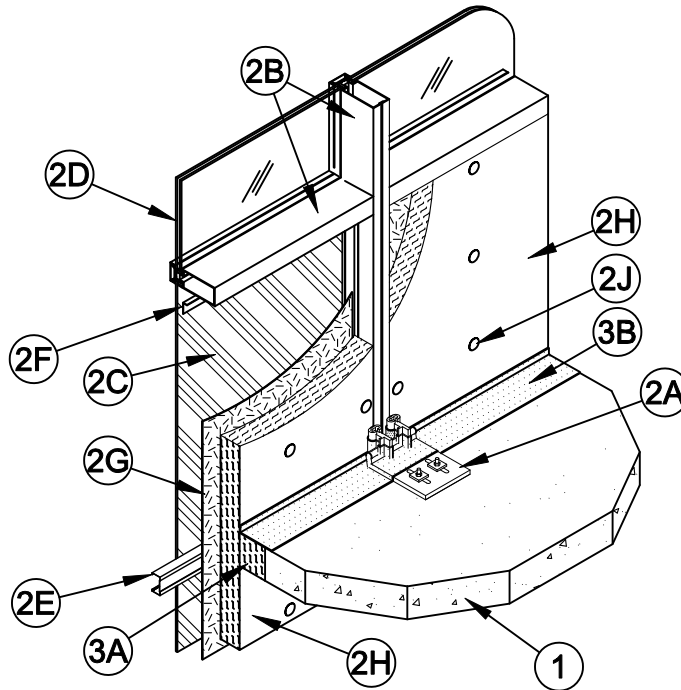

System No. CW-D-1002

F Rating - 2 Hr
 T Rating - 1/2 Hr
 Integrity Rating - 2 Hr
 Insulation Rating - 1/2 Hr
 Linear Opening Width - 4 In. Max
 L Rating At Ambient - Less Than 1 CFM/Lin Ft
 L Rating At 400°F - Less Than 1 CFM/Lin Ft
 Class II Movement Capabilities - 5% Vertical Shear



1. **Floor Assembly** - Min 4-1/2 in. thick reinforced lightweight or normal weight (100-150 pcf) structural concrete.
2. **Curtain Wall Assembly** - The factory-assembled curtain wall assembly shall incorporate the following construction features:
 - A. **Mullion Mounting Brackets** - Min 8 in. wide by 3/4 in. thick extruded aluminum Halfen mounting brackets with one nom 2 in. high leg for support and attachment of mullion and with one leg at least 6 in. longer than width of linear opening between floor assembly and mullion. Mounting bracket attached to top of floor with two min 1/2 in. diam steel masonry anchors in conjunction with washer plates supplied with mounting bracket.
 - B. **Framing** - The two-piece rectangular tubing mullions (vertical members) and transoms (horizontal members) shall be min 2-1/2 in. wide by 5 in. deep and shall be formed from min 0.100 in. thick aluminum. Mullions spaced max 30 in. OC and secured to mullion mounting anchors (Item 2A) at each floor level in conjunction with extruded aluminum clips bolted to the sides of the mullions and designed to engage the vertical leg of the Halfen mullion mounting bracket in conjunction with an extruded aluminum hook/leveling connector. Interior face of mullions to be max 4 in. from edge of floor assembly. Transoms to be spaced min 66 in. OC. Sill of vision panel to be located min 34 in. above top surface of floor assembly.
 - C. **Spandrel Panels** - The following types of spandrel panels are acceptable
 - a. **Glass Panels** - Nom 1/4 in. thick opaque heat-strengthened glass. Each panel secured in position with aluminum pressure plates in conjunction with glazing gaskets and steel screws.
 - b. **Aluminum Panels** - Nom 1/8 in. thick aluminum panels with 1/4 in. thick edges. Each panel secured in position with aluminum pressure plates in conjunction with gaskets and steel screws.
 - c. **Stone Panels** - Nom 1-3/16 in. thick polished granite spandrel panels with 1 in. thick gauged edges. Each panel secured in position with aluminum pressure plates in conjunction with gaskets and steel screws.
 - D. **Vision Panels** - Nom 1 in. thick (double pane) transparent heat-strengthened glass. Each panel secured in position with aluminum pressure plates in conjunction with glazing gaskets and steel screws.



Specified Technologies Inc. 210 Evans Way Somerville, NJ 08876

Reproduced courtesy of Underwriters Laboratories, Inc.
 Created or Revised: April 15, 2009

(800)992-1180 • (908)526-8000 • FAX (908)231-8415 • E-Mail:techserv@stifirestop.com • Website:www.stifirestop.com



CW-D-1002
 PAGE 1 OF 2

- E. **Steel Channels** - Nom 2-1/2 in. wide by 1-1/4 in. deep No. 20 gauge steel "C" shaped channels with min 5/16 in. long stiffening flanges. Steel channels provided with min 2 in. long flattened ends. Ends bent 90° and secured to aluminum mullions with No. 10 by 3/4 in. long self-drilling, self-tapping steel screws. Channels required at the middle of each spandrel panel. Channel additionally secured to steel backpan (Item 2G) with No. 10 by 3/8 in. self-drilling, self-tapping steel screws spaced 1 in. from each end and max 12 in. OC. Face of channels to be recessed 3 in. from interior face of mullion to accommodate curtain wall insulation.
- F. **Spandrel Panel Perimeter Angles** - Nom 1-1/2 by min 5/8 in. No. 20 gauge galvanized steel angles installed around entire perimeter of each spandrel panel. Angles recessed 3 in. from interior face of framing to accommodate curtain wall insulation (Item 2H). Min 5/8 in. leg of angles screw-attached to mullions and transom along sides and top of each spandrel panel with No. 8 by 1 in. long self-drilling, self-tapping steel screws spaced max 12 in. OC. Angle along bottom of each spandrel panel to be screw-attached to 1-1/2 in. wide leg of angle on mullion at each end without any direct attachment to transom.
- G. **Steel Backpan** - Min 20 gauge galvanized steel backpan attached to spandrel panel perimeter angles using No. 8 by 5/8 in. long self-drilling, self-tapping steel screws spaced max 12 in. OC. Backpan recessed 3 in. from interior face of framing to accommodate curtain wall insulation (Item 2H).
- H. **Curtain Wall Insulation*** - Nom 3 in. thick mineral wool batt insulation faced on one side with aluminum foil/scrim vapor retarder. Insulation batts to be installed with no vertical seams and with horizontal seams spaced min 36 in. OC. Insulation panels tightly-fitted between vertical mullions and the transoms, flush with the interior surface of framing. Insulation panels secured to steel backpan with cup head weld pins (Item 2J) spaced max 12 in. OC.
FIBREX INSULATIONS INC - FBX CW90 Curtain Wall Insulation
- I. **Framing Covers - Curtain Wall Insulation*** - (Not Shown) - Min 8 in. wide strips cut from min 1 in. thick mineral wool batt insulation faced on one side with aluminum foil/scrim vapor retarder. Framing covers to be centered over mullions and secured to the spandrel panel perimeter angles with cup head weld pins spaced max 12 in. OC below the level of the floor. Where more than one spandrel panel occurs between vertically separated vision panels, the horizontal transom between spandrel panels shall also be covered with a min 8 in. wide framing cover in the same manner as on the vertical mullions. Framing covers on mullions to abut the mineral wool batt safing material (Item 3A) below floor.
FIBREX INSULATIONS INC - FBX CW90 Curtain Wall Insulation
- J. **Weld Pin** - Nom 3 in. long No. 12 gauge galv steel weld pin with nom 1-3/16 in. diam galv steel cup head used to secure curtain wall insulation and framing covers. Cup head weld pins inserted through mullion covers and curtain wall insulation and welded to steel channels. As an alternate, nom 4-1/2 in. long self-drilling, self-tapping steel screws with min 1-1/2 in. diam galv steel clinch shields or self-locking washers may be used.
3. **Safing System - Max separation between edge of floor assembly and face of framing member at time of installation is 4 in. The safing system is designed to accommodate vertical shear up to 5 percent of its installed width.** The safing system shall incorporate the following construction features:
- A. **Forming Material*** - Nom 4 pcf density mineral wool batt insulation. Batt sections cut to a width of 4-1/2 in. and stacked to a thickness which is min 50 percent greater than the width of the linear gap between the curtain wall insulation and the edge of the concrete floor slab. The forming material is compressed min 33 percent and inserted cut-edge-first into the linear gap such that its top surface is flush with the top surface of the floor assembly. Adjoining lengths of forming material to be tightly butted with butted seams spaced min 24 in. OC. Forming material to be continuous beneath mullion mounting brackets (Item 2A).
FIBREX INSULATIONS INC - FBX Safing Insulation
THERMAFIBER INC - SAF
- B. **Fill, Void or Cavity Material*** - Min 1/8 in. wet thickness (1/16 in. dry thickness) of fill material spray-applied over top of forming material and lapping min 1/2 in. onto the top surface of the floor and onto the curtain wall insulation and framing covers.
SPECIFIED TECHNOLOGIES INC - SpecSeal AS200 Elastomeric Spray or SpecSeal Fast Tack Spray
 *Bearing the UL Classification Mark



Specified Technologies Inc. 210 Evans Way Somerville, NJ 08876

Reproduced courtesy of Underwriters Laboratories, Inc.

Created or Revised: April 15, 2009

(800)992-1180 • (908)526-8000 • FAX (908)231-8415 • E-Mail:techserv@stifirestop.com • Website:www.stifirestop.com



CW-D-1002
PAGE 2 OF 2