

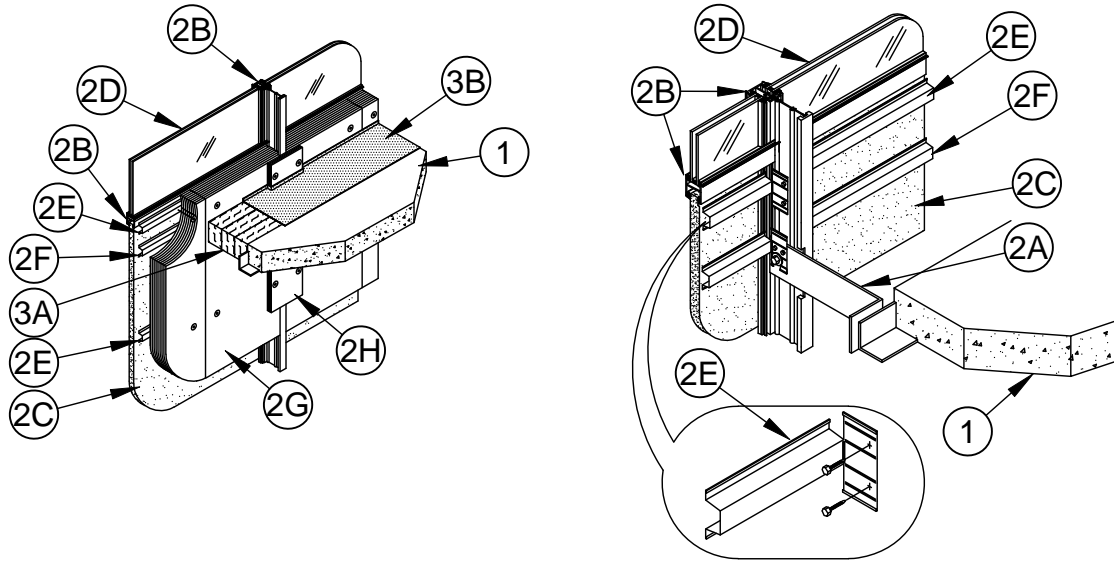

**System No. CW-D-2003**

F Ratings - 1-1/2 and 2 Hr (See Item 2B)  
 T Rating - 1/2 Hr  
 Integrity Ratings - 1-1/2 and 2 Hr (See Item 2B)  
 Insulation Rating - 1/2 Hr  
 Linear Opening Width - 10 In. Max  
 L Rating At Ambient - Less Than 1 CFM/Lin Ft  
 L Rating At 400°F - Less Than 1 CFM/Lin Ft  
 Class II Movement Capabilities - 5% Vertical Shear (See Item 3)



1. **Floor Assembly** - Min 4-1/2 in. thick reinforced lightweight or normal weight (100-150 pcf) structural concrete. Perimeter of floor assembly to be provided with min 3 by 3 by 1/4 in. thick cast-in-place structural steel angle for weld-attachment of mullion mounting clips (Item 2A).
2. **Curtain Wall Assembly** - The curtain wall assembly shall incorporate the following construction features:
  - A. **Mullion Mounting Clips** - Min 4 in. long angles with one nom 4 in. leg for attachment to edge of floor assembly and with one leg approx 4 in. longer than distance to nearest face of mullion. Clips to be formed of min 1/4 in. thick steel. Clip welded to steel angle at edge of floor assembly (Item 1) on one side of each vertical mullion (Item 2B) at each floor level. Each clip to be provided with elongated holes to accommodate designed amount of movement. Top edge of each clip to be recessed min 1/2 in. below top surface of floor.
  - B. **Framing** - The "I" shaped mullions (vertical members) shall be min 2-1/2 in. wide by 7 in. deep and shall be formed from min 0.125 in. thick aluminum. The horizontal framing members shall be min 2 in. wide by 2 in. deep and formed from min 0.125 in. thick aluminum. Mullions spaced max 60 in. OC and secured to mullion mounting clips (Item 2A) at each floor level with two min 3/8 in. diameter hex head steel bolts in conjunction with steel nuts and washers. Interior face of mullions to be notched to accommodate mullion mounting clips and desired movement and to be max 10 in. from edge of floor assembly. Horizontal framing members to be spaced min 72 in. OC. The Integrity Rating is dependent upon the minimum height from the top of the floor to the bottom of the vision panel sill, as tabulated below:

Min Vision Panel Sill Height Above Floor, in.	Integrity Rating, Hr
6	1-1/2
34	2



**Specified Technologies Inc. 210 Evans Way Somerville, NJ 08876**

Reproduced courtesy of Underwriters Laboratories, Inc.  
 Created or Revised: May 23, 2008

(800)992-1180 • (908)526-8000 • FAX (908)231-8415 • E-Mail:techserv@stifirestop.com • Website:www.stifirestop.com



CW-D-2003  
 PAGE 1 OF 2

- C. **Spandrel Panels** - Nom 1-3/16 in. thick polished granite panels with 1 in. thick edges. Each panel secured in position and four-side captured with exterior sponge gasket compressed in place with interior wedge rubber and aluminum glazing bead.
- D. **Vision Panels** - Nom 1 in. thick (double pane) transparent heat-strengthened glass panels. Each panel secured in position and four-side captured with exterior sponge gasket compressed in place with interior wedge rubber and aluminum glazing bead.
- E. **Steel Hat Channels** - Nom 2-1/2 in. wide by 7/8 in. deep No. 24 gauge galvanized steel hat channel installed to span from mullion-to-mullion for attachment of curtain wall insulation (Item 2G). Hat channels to be cut min 4 in. longer than on center spacing of mullions. Ends of hat channels cut, flattened and bent 90 deg to form min 2 in. long tabs for screw-attachment to mullions with No. 10 by 1 in. long self-drilling, self-tapping steel screws. Hat channels installed max 3 in. above top of vision panel, max 3 in. below bottom of vision panel and spaced max 24 in. OC. Hat channels screw-attached to mullions along sides of each spandrel panel with No. 10 by 1 in. long self-drilling, self-tapping steel screws.
- F. **Stiffener Channel** - One nom 2-1/2 in. wide by 7/8 in. deep by 24 gauge (or heavier) steel hat-channel installed to span between mullions at each floor level to restrain curtain wall insulation against outward movement when forming material (Item 3A) is installed. Stiffener channel to be cut min 4 in. longer than on center spacing between mullions. Ends of stiffener channel cut, flattened and bent 90 deg to form min 2 in. long tabs for screw-attachment to the mullion mounting clips (Item 2E) with No. 10 by 3/4 in. long self-drilling, self-tapping steel screws. Each stiffener channel shall be located with its stem centerline at an elevation 2 in. below the top plane of the floor.
- G. **Curtain Wall Insulation\*** - Nom 4 in. thick mineral wool batt insulation faced on one side with aluminum foil/ scrim vapor retarder, supplied in min 72 in. long batts. Insulation batts compression-fitted between vertical mullions, flush with the interior surface of framing, with a maximum of one vertical seam and with no horizontal seams. Insulation panels secured to each hat channel with min 4-1/2 in. long steel screws with min 1-1/2 in. diameter galv steel clinch shields spaced 3 in. from each vertical edge of batt.

**THERMAFIBER INC - FIRESpan 40**

- H. **Mullion Insulation - Curtain Wall Insulation\*** - Min 8 in. wide strips cut from min 1 in. thick mineral wool batt insulation. Framing covers to be centered over mullions and secured to the steel hat channels with min 5-1/2 in. long steel screws. Framing covers on mullions to abut the mineral wool batt safig material (Item 3A) above and below floor.

**THERMAFIBER INC - FIRESpan 90**

- 3. **Safing System - Max separation between edge of floor assembly and face of framing members (at time of installation) is 10 in. The safig system is designed to accommodate vertical shear movement up to a max of 5 percent of its installed width.** The safig system shall incorporate the following construction features:

- A. **Forming Material\*** - Nom 4 pcf density mineral wool batt insulation. Batt sections cut to a 4 in. width and stacked to a thickness which is min 20 percent greater than the width of the linear gap between the curtain wall insulation and the edge of the concrete floor slab. The forming material is compressed and inserted cut-edge-first into linear gap such that its top surface is flush with the top surface of the floor assembly. A max of one tightly-butted seam is permitted between mullions. Additional piece of forming material to be friction-fit into gap between batt sections above mullion mounting clip at each mullion location.

**THERMAFIBER INC - SAF**

- B. **Fill, Void or Cavity Material\*** - Min 1/8 in. wet thickness (min 1/16 in. dry thickness) of fill material spray-applied over top of forming material and lapping min 1/2 in. onto the top surface of the floor and onto the curtain wall insulation and mullion covers.

**SPECIFIED TECHNOLOGIES INC - SpecSeal AS200 Elastomeric Spray or SpecSeal Fast Tack Spray**

\*Bearing the UL Classification Mark



**Specified Technologies Inc. 210 Evans Way Somerville, NJ 08876**

Reproduced courtesy of Underwriters Laboratories, Inc.

Created or Revised: May 23, 2008

(800)992-1180 • (908)526-8000 • FAX (908)231-8415 • E-Mail:techserv@stifirestop.com • Website:www.stifirestop.com



CW-D-2003  
PAGE 2 OF 2