



System No. FF-D-0015

Assembly Rating - 4 Hr

Nominal Joint Width - 2 in.

L Rating At Ambient - Less Than 1 CFM/Lin Ft

L Rating At 400°F - Less Than 1 CFM/Lin Ft

Class II Movement Capabilities - 12.5% Compression or Extension

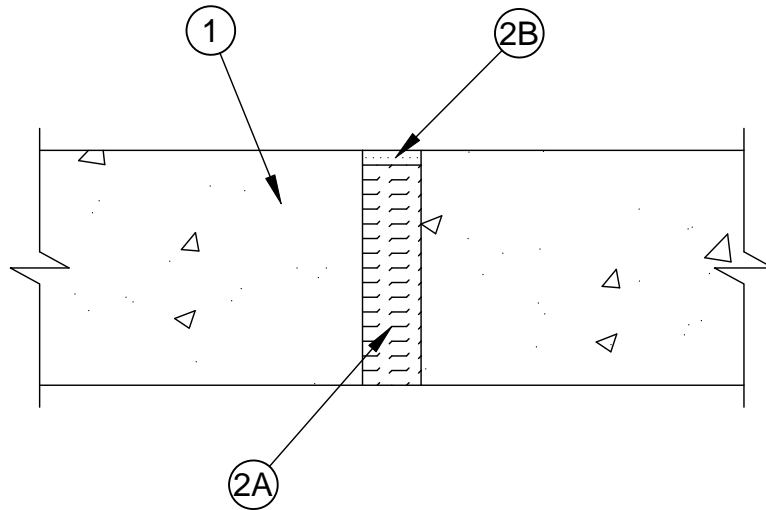

1. **Floor Assembly** - Min 5-1/2 in. (140 mm) thick reinforced lightweight or normal weight (100-150 pcf or 1600-2400 kg/m³) structural concrete.
2. **Joint System** - Max width of joint (at time of installation of joint system) is 2 in. (51 mm). The joint system is designed to accommodate a max 12.5 percent compression or extension from its installed width. The joint system shall consist of forming and fill materials, as follows:

A. **Forming Material*** - Min 4 pcf (64 kg/m³) mineral wool batt insulation installed in joint opening as a permanent form. Pieces of batt cut to min 5 in. (127 mm) width and installed edge-first into joint opening, parallel with joint direction, such that batt sections are compressed min 50 percent in thickness and such that the compressed batt sections are recessed from the top surface of the floor as required to accommodate the required thickness of fill material. Adjoining lengths of batt to be tightly butted with butted seams spaced min 16 in. (406 mm) apart along the length of the joint.

FIBREX INSULATIONS INC - FBX Safing Insulation

IIG MINWOOL L L C - MinWool-1200 Safing

ROCK WOOL MANUFACTURING CO - Delta Board

ROCKWOOL MALAYSIA SDN.BHD - SAFE

ROXUL INC - SAFE

THERMAFIBER INC - Type SAF

B. **Fill, Void or Cavity Material* - Sealant** - Min 1/2 in. (13 mm) thickness of fill material applied within the joint, flush with top surface of floor.

SPECIFIED TECHNOLOGIES INC - SpecSeal ES Sealant

*Bearing the UL Classification Mark



Specified Technologies Inc. 210 Evans Way Somerville, NJ 08876

Reproduced courtesy of Underwriters Laboratories, Inc.

Created or Revised: April 19, 2011

(800)992-1180 • (908)526-8000 • FAX (908)231-8415 • E-Mail:techserv@stifirestop.com • Website:www.stifirestop.com



FF-D-0015
PAGE 1 OF 1