



### System No. F-A-1118

F Rating - 2 Hr

T Rating - 2 Hr

L Rating At Ambient - Less Than 1 CFM/sq ft (See Items 3 and 6)

L Rating At 400 F - Less Than 1 CFM/sq ft (See Items 3 and 6)

W Rating - Class 1 (See Item 6)

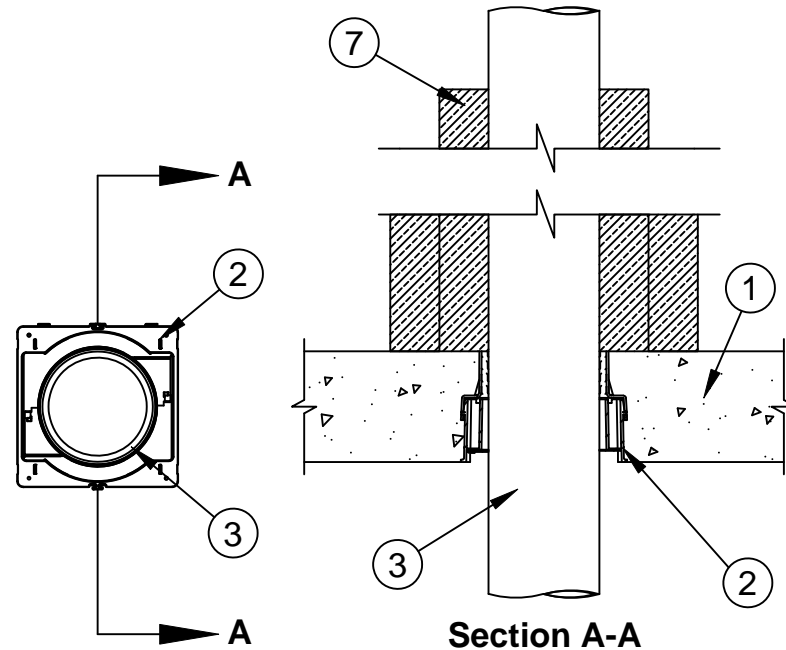

- 1. **Floor Assembly** - Min 4-1/2 in. (114 mm) thick reinforced lightweight or normal weight (100-150 pcf or 1600-2400 kg/m<sup>3</sup>) concrete floor.
- 1A. **Alternate Floor Assembly** - (Not Shown) - The fire rated unprotected concrete and steel floor assembly shall be constructed of the material and in the manner specified in the individual D900 Series designs in the UL Fire Resistance Directory and as summarized below:
  - A. **Concrete** - Min 4-1/2 in. (114 mm) thick reinforced lightweight or normal weight (100-150 pcf or 1600-2400 kg/m<sup>3</sup>) concrete, as measured from the top plane of the steel floor units.
  - B. **Steel Floor and Form Units\*** - Steel Floor and Form Units\* - Composite or non-composite max 3 in. (76 mm) deep galv steel fluted units as specified in the individual Floor-Ceiling Design.
- 2. **Firestop Device\*** - Cast in place firestop device permanently embedded during the concrete pour or grouted into the concrete assembly in accordance with the accompanying installation instructions. The throat of the firestop device may be cut flush with the top surface of the floor or extend beyond the top surface of the floor.

**SPECIFIED TECHNOLOGIES INC** - SpecSeal CD200, CD200M, CD300, CD300M, CD400 or CD400M Cast In Firestop Device

- 2A. **Firestop Device\*** - (Not Shown) - When Item 1A is used, a steel deck adapter kit consisting of steel plates and a nonmetallic extension tube is used in conjunction with Item 2. Install the deck adapter in accordance with the accompanying installation instructions.

**SPECIFIED TECHNOLOGIES INC** - SpecSeal CD200DK, CD300DK, or CD400DK Cast In Firestop Device Deck Adapter



**Specified Technologies Inc. 210 Evans Way Somerville, NJ 08876**

Reproduced courtesy of Underwriters Laboratories, Inc.

Created or Revised: February 17, 2010

(800)992-1180 • (908)526-8000 • FAX (908)231-8415 • E-Mail:techserv@stifirestop.com • Website:www.stifirestop.com



F-A-1118  
PAGE 1 OF 2

- 2B. **Firestop Device\*** - (Not Shown) - When the concrete thickness exceeds 8 in. (204 mm), a nonmetallic extension tube is used in conjunction with Item 2. Install the extension tube in accordance with the accompanying installation instructions.

**SPECIFIED TECHNOLOGIES INC** - SpecSeal CD200X, CD300X, or CD400X Cast In Firestop Device Extension

3. **Through Penetrants** - One metallic pipe, tube, or conduit to be installed within the firestop system. Pipe or conduit to be rigidly supported on both sides of the floor assembly. The following types and sizes of the metallic pipes or conduits may be used:
- A. **Steel Pipes** - Nom 4 in. (102 mm) diam (or smaller) Schedule 10 (or heavier) steel pipe.
  - B. **Iron Pipes** - Nom 4 in. (102 mm) diam (or smaller) cast or ductile iron pipe.
  - C. **Conduit** - Nom 4 in. (102 mm) rigid steel conduit or steel electrical metallic tubing (EMT).
  - D. **Copper Pipes or Tubing** - Nom 4 in. (102 mm) diam (or smaller) Type M (or heavier) or Regular (or heavier) copper pipe or tube.

Nom Pipe Diam+	Firestop Device
1-1/2 or 2 in. (38 or 51 mm)	CD200 or CD200M
2-1/2 or 3 in. (64 or 76 mm)	CD300 or CD300M
3-1/2 or 4 in. (89 or 102 mm)	CD400 or CD400M

+When metallic pipe, conduit, or tubing with diam smaller than those shown in the table above are used, packing material and/or fill material shall be installed into the device as described in Items 4 and 5. L Ratings for these penetrants only apply when the fill material is used. Otherwise, the L Rating for each firestop device is less than 1 cfm at ambient and at 400F.

4. **Packing Material** - (Not Shown) - When required under Item 3, min 4 in. (102 mm) thickness of min 4 pcf (64 kg/m<sup>3</sup>) mineral wool firmly packed into device flush with top edge of device (Item 2). When W or L Ratings are required for penetrants with a diam smaller than those shown in the table above, recess mineral wool 1/4 in. (6 mm) from top edge of device to accommodate sealant (Item 6).
5. **Fill, Void, or Cavity Material\*** - Putty - (Not Shown) - When required under Item 3, as an option to Item 4, min 1 in. (25 mm) depth of fill material applied within device flush with top edge of device (Item 2).

**SPECIFIED TECHNOLOGIES INC** - SpecSeal Putty

6. **Fill, Void, or Cavity Material\*** - (Optional, Not Shown) - To achieve W or L Ratings for penetrants with a diam smaller than those shown in the table of Item 3, apply min 1/4 in. (6 mm) depth of sealant atop packing material (Item 4) flush with top edge of device.

**SPECIFIED TECHNOLOGIES INC** - Pensil 300 Silicone Sealant, Pensil 300SL Silicone Sealant, SpecSeal Series SIL 300 Sealant or SpecSeal SIL 300SL Sealant

7. **Duct Wrap Material\*** - Nom 2 in. (51 mm) thick duct wrap tightly wrapped around penetrant to extend 36 in. (914 mm) above floor. An additional layer of nom 2 in. (51 mm) thick duct wrap tightly wrapped around the first layer of duct wrap to extend 12 in. (305 mm) (914 mm) above floor. All longitudinal seams of both layers of duct wrap are sealed with foil tape.

**THERMAL CERAMICS INC** - FireMaster® Duct Wrap 2x2, FireMaster Duct Wrap 2x2+, FireMaster FastWrap XL, or Pyroscat Duct Wrap XL

\*Bearing the UL Classification Mark

+Bearing the UL Listing Mark



**Specified Technologies Inc. 210 Evans Way Somerville, NJ 08876**

Reproduced courtesy of Underwriters Laboratories, Inc.  
Created or Revised: February 17, 2010

(800)992-1180 • (908)526-8000 • FAX (908)231-8415 • E-Mail:techserv@stifirestop.com • Website:www.stifirestop.com



F-A-1118  
PAGE 2 OF 2