

System No. F-C-1014

F Rating - 2 Hr

T Ratings - 1/2 and 1-1/2Hr (See Item 3)

L Rating At Ambient - Less Than 1 CFM/sq ft

L Rating At 400 F - Less Than 1 CFM/sq ft

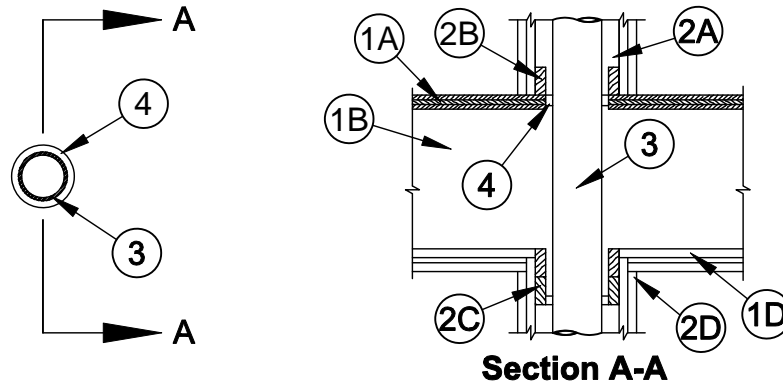

Section A-A

- Floor-Ceiling Assembly** - The 2 hr fire-rated joist floor-ceiling assembly shall be constructed of the materials and in the manner specified in Design Nos. L505, L511, or L536, in the UL Fire Resistance Directory, as summarized below:
 - Flooring System** - Lumber or plywood subfloor with finish floor of lumber, plywood or **Floor Topping Mixture*** as specified in the individual Floor-Ceiling Design. Max diam of floor opening is 4-1/4 in. (108 mm).
 - Wood Joists** - Nom 2 by 10 in. (51 by 254 mm) lumber joists spaced 16 in. (406 mm) OC with nom 1 by 3 in. (25 by 76 mm) lumber bridging and with ends firestopped.
 - Furring Channels** - (Not Shown) - Resilient galv steel furring installed perpendicular to wood joists between first and second layers of wallboard (Item 1D) and spaced max 24 in. (610 mm) OC.
 - Gypsum Board*** - Two layers 5/8 in. (16 mm) thick as specified in the individual Floor-Ceiling Design. First layer of wallboard nailed to wood joists. Second layer of wallboard screw-attached to furring channels. Max diam of floor opening is 4-1/4 in. (108 mm).
- Chase Wall** - (Optional) - The through penetrant (Item 3) may be routed through a 2 hr fire-rated single, double or staggered wood stud/gypsum wallboard chase wall constructed of the materials and in the manner specified in the individual U300 Series Wall and Partition Designs in the UL Fire Resistance Directory and shall include the following construction features:
 - Studs** - Nom 2 by 6 in. (51 by 152 mm) or double nom 2 by 4 in. (51 by 102) lumber studs.
 - Sole Plate** - Nom 2 by 6 in. (51 by 152 mm) or parallel 2 by 4 in. (51 by 102) lumber plates, tightly butted.
 - Top Plate** - The double top plate shall consist of two nom 2 by 6 in. (51 by 152 mm) or two sets of parallel 2 by 4 in. (51 by 102) lumber plates, tightly butted. Max diam of opening is 4-1/4 in. (108 mm).
 - Gypsum Board*** - Thickness, type, number of layers and fasteners shall be as specified in individual Wall and Partition Design.
- Through Penetrants** - One metallic pipe, conduit or tubing to be installed within the firestop system. Pipe, conduit or tubing to be rigidly supported on both sides of floor assembly. The annular space within the firestop system shall be min 0 in. (point contact) to max 3/4 in. (19 mm). The following types and sizes of metallic pipes or conduits may be used:
 - Steel Pipe** - Nom 3 in. (76 mm) diam (or smaller) Schedule 10 (or heavier) steel pipe.
 - Conduit** - Nom 3 in. (76 mm) diam (or smaller) steel electrical metallic tubing or steel conduit.
 - Iron Pipe** - Nom 3 in. (76 mm) diam (or smaller) cast or ductile iron pipe.
 - Copper Tubing** - Nom 3 in. (76 mm) diam (or smaller) Type L (or heavier) copper tubing.
 - Copper Pipe** - Nom 3 in. (76 mm) diam (or smaller) Regular (or heavier) copper pipe.

The T Rating is 1-1/2 Hr for Penetrants A, B and C. The T Rating is 1/2 Hr for Penetrants D and E.

- Fill, Void or Cavity Material* - Sealant** - Min 3/4 in. (19 mm) thickness of fill material applied within the annulus, flush with top surface of floor or sole plate. Min 5/8 in. (16 mm) thickness of fill material also applied within the annulus of the ceiling or top plate, flush with bottom surface of the ceiling or lower top plate. Min 3/8 in. (10 mm) diam bead of fill material applied at point contact location on top surface of floor or sole plate and on bottom surface of gypsum board ceiling or lower top plate

SPECIFIED TECHNOLOGIES INC - SpecSeal Series SSS Sealant or SpecSeal LCI Sealant

*Bearing the UL Classification Mark



Specified Technologies Inc. 210 Evans Way Somerville, NJ 08876

Reproduced courtesy of Underwriters Laboratories, Inc.

Created or Revised: January 2, 2009

(800)992-1180 • (908)526-8000 • FAX (908)231-8415 • E-Mail:techserv@stifirestop.com • Website:www.stifirestop.com



F-C-1014
PAGE 1 OF 1