

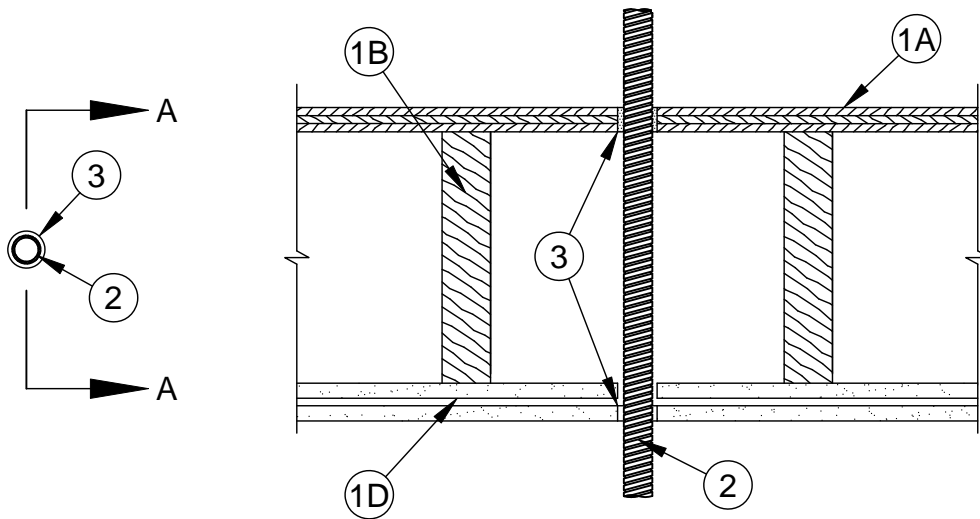

## System No. F-C-3041

F Ratings - 1 and 2 Hr (See Item 2A)  
T Ratings - 3/4, 1 and 2 Hr (See Item 2A)  
L Rating At Ambient - Less than 1 CFM/sq ft  
L Rating at 400 F - Less than 1 CFM/sq ft



Section A-A

1. **Floor-Ceiling Assembly** - The 1 hr fire-rated solid or trussed lumber joist floor-ceiling assembly shall be constructed of the materials and in the manner specified in the individual L500 Series Floor-Ceiling Designs in the UL Fire Resistance Directory. The 2 hr fire-rated wood joist floor-ceiling assembly shall be constructed of the materials and in the manner specified in Design Nos. L505, L511 or L536 in the UL Fire Resistance Directory. The general construction features of the floor-ceiling assembly are summarized below:
  - A. **Flooring System** - Lumber or plywood subfloor with finish floor of lumber, plywood or **Floor Topping Mixture\*** as specified in the individual Floor-Ceiling Design. Max diam of floor opening is 2 in.
  - B. **Wood Joists\*** - For 1 hr fire-rated floor-ceiling assemblies nom 10 in. deep (or deeper) lumber, steel or combination lumber and steel joists, trusses or **Structural Wood Members\*** with bridging as required and with ends firestopped. For 2 hr fire-rated floor-ceiling assemblies, nom 2 by 10 in. lumber joists spaced 16 in. OC with nom 1 by 3 in. lumber bridging and with ends firestopped.
  - C. **Furring Channels - (Not Shown)** - In 2 hr fire-rated assemblies, resilient galv steel furring installed perpendicular to wood joists between first and second layers of wallboard (Item 1D). Furring channels spaced max 24 in. OC. In 1 hr fire-rated assemblies, resilient galv steel furring installed perpendicular to wood joists between wallboard and wood joists as specified in the individual Floor-Ceiling Design. Furring channels spaced max 24 in. OC. In 1 hr fire-rated assemblies, resilient galv steel furring installed perpendicular to wood joists between wallboard and wood joists as specified in the individual Floor-Ceiling Design. Furring channels spaced max 24 in. OC.
  - D. **Gypsum Board\*** - Nom 4 ft wide by 5/8 in. thick as specified in the individual Floor-Ceiling Design. First layer of wallboard secured to wood joists or furring channels as specified in the individual Floor-Ceiling Design. Second layer of wallboard (2 hr fire-rated assembly) screw-attached to furring channels as specified in the individual Floor-Ceiling Design. Max diam of ceiling opening is 2 in.



**Specified Technologies Inc. 210 Evans Way Somerville, NJ 08876**

Reproduced courtesy of Underwriters Laboratories, Inc.  
Created or Revised: January 2, 2009

(800)992-1180 • (908)526-8000 • FAX (908)231-8415 • E-Mail:techserv@stifirestop.com • Website:www.stifirestop.com



F-C-3041  
PAGE 1 OF 2

- 1.1 **Chase Wall** - (Not Shown, Optional) The through penetrants (Item 2) may be routed through a fire-rated single, double or staggered wood stud/gypsum wallboard chase wall having a fire rating consistent with that of the floor-ceiling assembly. The chase wall shall be constructed of the materials and in the manner specified in the individual U300 Series Wall and Partition Designs in the UL Fire Resistance Directory and shall include the following construction features:
- A. **Studs** - Nom 2 by 6 in. or double nom 2 by 4 in. lumber studs.
  - B. **Sole Plate** - Nom 2 by 6 in. or parallel 2 by 4 in. lumber plates, tightly butted.
  - C. **Top Plate** - The double top plate shall consist of two nom 2 by 6 in. or two sets of parallel 2 by 4 in. lumber plates, tightly butted. Max diam of opening is 2 in.
  - D. **Gypsum Board\*** - Thickness, type, number of layers and fasteners shall be as specified in individual Wall and Partition Design.
2. **Through Penetrating Product\*** - Max 4/C No. 5 AWG (or smaller) aluminum or steel **Metal-Clad Cable+** with copper conductors. Max one metal-clad cable to be installed either concentrically or eccentricity within the firestop system. One cable to be installed approximately midway between wood joist. Diam of openings hole-sawed through flooring system and through gypsum wallboard ceiling to be nom 3/8 in. larger than the outside diam of cable. The annular space within the firestop system shall be a min 0 in. (point contact) to a max 3/8 in. Through-penetrating product to be rigidly supported on both sides of a floor-ceiling assembly.

**NORTHERN CABLES INC**

- 2A. **Cables - (Not Shown) - As an alternate to Item 2** - One or more cables to be installed either concentrically or eccentricity within the firestop system. Cable(s) to be installed approximately midway between wood joist. Diam of openings hole-sawed through flooring system and through gypsum wallboard ceiling to be nom 3/8 in. larger than the outside diam of cable or cable bundle. The annular space within the firestop system shall be a min 0 in. (point contact) to a max 3/8 in. Cables to be rigidly supported on both sides of floor-ceiling assembly. The following types and sizes of cables may be used:
- A. Max 100 pair No. 24 AWG (or smaller) copper conductor telephone cables with polyvinyl chloride (PVC) insulation and jacket materials.
  - B. Max 3/C (with ground) No. 5 (or smaller) AWG aluminum conductor service entrance cable with PVC insulation and jacket materials.
  - C. Max 3/C (with ground) No. 12 AWG (or smaller) copper conductor nonmetallic sheathed (Romex) cable with PVC insulation and jacket materials.

The number of cables allowed within the opening is dependent upon the type and size of cable as tabulated in Item 2.

The F and T Ratings of the firestop system are dependent upon the hourly rating of the floor-ceiling and type and number of through penetrants, as tabulated below:

Rating of Assembly Hr	Type of Thought Penetrant	Max No. of Penetrants	F Rating Hr	T Rating Hr
1	Telephone Cable	1	1	1
2	Telephone Cable	1	2	2
1	Service Entrance Cable	7	1	1
1	Romex Cable	1	1	3/4
1	Metal Clad Cable	1	1	3/4

3. **Fill, Void or Cavity Material\* - Sealant** - On top surface of floor, min 3/4 in. thickness of fill material applied within annulus, flush with top surface of floor. On bottom surface of ceiling, min 5/8 in. thickness of fill material applied within annulus, flush with bottom surface of ceiling or lower top plate of chase wall assembly. Additional fill material to be installed such that a min 1/8 in. crown is formed around the penetrating item on bottom surface of ceiling or lower top plate of chase wall assembly. On both top and bottom of assembly, fill material forced into interstices of cable group to max extent possible.

**SPECIFIED TECHNOLOGIES INC** - SpecSeal Series SSS Sealant or SpecSeal LCI Sealant

\*Bearing the UL Classification Mark



**Specified Technologies Inc. 210 Evans Way Somerville, NJ 08876**

Reproduced courtesy of Underwriters Laboratories, Inc.

Created or Revised: January 2, 2009

(800)992-1180 • (908)526-8000 • FAX (908)231-8415 • E-Mail:techserv@stifirestop.com • Website:www.stifirestop.com



F-C-3041  
PAGE 2 OF 2