

System No. F-C-5014

F Rating - 1 Hr

T Ratings - 3/4 and 1 Hr (See Item 4)

L Rating at Ambient - Less Than 1 CFM/sq ft

L Rating at 400° F - Less Than 1 CFM/sq ft

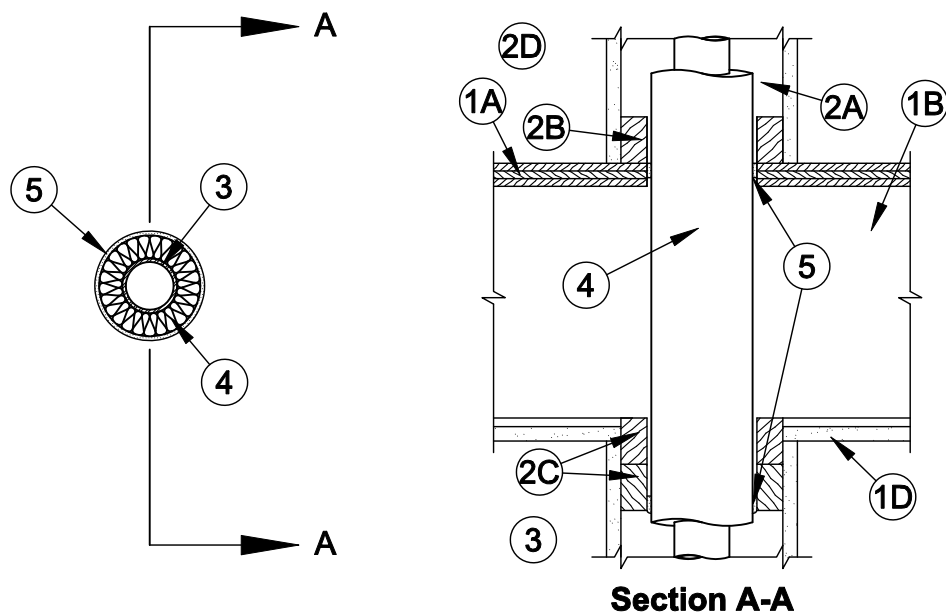

- Floor-Ceiling Assembly** - The fire-rated solid or trussed lumber joist floor-ceiling assembly shall be constructed of the materials and in the manner specified in individual L500 Series Floor-Ceiling Designs in the UL Fire Resistance Directory. The general construction details of the floor-ceiling assembly are summarized below:
 - Flooring System** - Lumber or plywood subfloor with finish floor of lumber, plywood or **Floor Topping Mixture*** as specified in the individual Floor-Ceiling Design. Max diam of floor opening is 4-3/4 in. (121 mm).
 - Wood Joists** - Nom 2 by 10 in. (51 by 254 mm) lumber joists spaced 16 in. (406 mm) OC with nom 1 by 3 in. (25 by 76 mm) lumber bridging and with ends firestopped. As an alternate to lumber joists, nom 10 in. (254 mm) deep (or deeper) lumber, steel or combination lumber and steel joists, trusses or **Structural Wood Members*** with bridging as required with ends firestopped.
 - Furring Channels** - (Not Shown) - Resilient galv steel furring installed perpendicular to wood joists (Item 1B) between gypsum board (Item 1D) and wood joists or furring channels as required in the individual Floor-Ceiling Design.
 - Gypsum Board*** - Nom 4 ft (1.2 m) wide by 5/8 in. (16 mm) thick as specified in the individual Floor-Ceiling Design. Gypsum board secured to wood joists or furring channels as specified in the individual Floor-Ceiling Design.
- Chase Wall** - (Optional) - The through penetrants (Item 3) may be routed through the fire-rated single, double or staggered wood stud/gypsum board chase wall constructed of the materials and in the manner specified in the individual U300 Series Wall and Partition Designs in the UL Fire Resistance Directory and shall include the following construction features:
 - Studs** - Nom 2 by 6 in. (51 by 152 mm) or double nom 2 by 4 in. (51 by 102 mm) lumber studs.
 - Sole Plate** - Nom 2 by 6 in. (51 by 152 mm) or parallel 2 by 4 in. (51 by 102 mm) lumber plates, tightly butted.
 - Top Plate** - The double top plate shall consist of two nom 2 by 6 in. (51 by 152 mm) or two sets of parallel 2 by 4 in. (51 by 102 mm) lumber plates, tightly butted. Max diam of opening is 4-3/4 in. (121 mm).
 - Gypsum Board*** - Thickness, type, number of layers and fasteners shall be as specified in individual Wall and Partition Design.
- Through Penetrant** - One metallic pipe or tubing to be installed approximately midway between wood joists and centered within the firestop system. Pipe or tubing to be rigidly supported on both sides of floor-ceiling assembly. The following types and sizes of metallic pipes or tubing may be used:
 - Steel Pipe** - Nom 2 in. (51 mm) diam (or smaller) Schedule 10 (or heavier) steel pipe.
 - Copper Tubing** - Nom 2 in. (51 mm) diam (or smaller) Type L (or heavier) copper tubing.
 - Copper Pipe** - Nom 2 in. (51 mm) diam (or smaller) Regular (or heavier) copper pipe.



Specified Technologies Inc. 210 Evans Way Somerville, NJ 08876

Reproduced courtesy of Underwriters Laboratories, Inc.

Created or Revised: January 2, 2009

(800)992-1180 • (908)526-8000 • FAX (908)231-8415 • E-Mail:techserv@stifirestop.com • Website:www.stifirestop.com



F-C-5014
PAGE 1 OF 2

4. **Pipe Coverings*** - One of the following types of pipe coverings shall be used:

A. **Pipe and Equipment Covering - Materials*** - Nom 1 in. (25 mm) thick hollow cylindrical heavy density (nom 3.5 pcf or 56 kg/m³) glass fiber units jacketed on the outside with an all service jacket. Longitudinal joints sealed with metal fasteners or factory-applied self-sealing lap tape. Transverse joints secured with metal fasteners or with butt tape supplied with the product. The annular space between the insulated through penetrant and periphery opening shall be a nom 5/16 in. (8 mm).

See **Pipe and Equipment Covering-Materials** - (BRGU) category in the Building Materials Directory for names of manufacturers. Any pipe covering material meeting the above specifications and bearing the UL Classification Marking with a Flame Spread Index of 25 or less and a Smoke Developed Index of 50 or less may be used:

B. **Pipe Covering Materials*** - Nom 1 in. (25 mm) thick unfaced mineral fiber pipe insulation sized to the outside diam of pipe or tube. Pipe insulation secured with min 18 AWG steel wire spaced max 12 in. (305 mm) OC. The annular space between the insulated through penetrant and periphery opening shall be a nom 5/16 in. (8 mm).

IIG MINWOOL L L C - High Temperature Pipe Insulation 1200, High Temperature Pipe Insulation BWT or High Temperature Pipe Insulation Thermaloc.

C. **Sheathing Material*** - Used in conjunction with Item 4B. Foil-scrim-kraft or all service jacket material shall be wrapped around the outer circumference of the pipe insulation (Item 3B) with the kraft side exposed. Longitudinal joints and transverse joints sealed with metal fasteners or butt tape.

See **Sheathing Materials** (BVDV) category in the Building Materials Directory for names of manufacturers. Any sheathing material meeting the above specifications and bearing the UL Classification Marking with a Flame Spread Index of 25 or less and a Smoke Developed Index of 50 or less may be used.

D. **Tube Insulation - Plastics+** - (Not Shown) - Nom 1/2 in. (13 mm) thick acrylonitrile butadiene/polyvinyl chloride (AB/PVC) flexible foam furnished in the form of tubing. The annular space within the firestop system shall be a nom 7/16 in. (11 mm).

See **Plastics+** (QMFZ2) category in the Recognized Component Directory for names of manufacturers. Any Recognized Component tube insulation material meeting the above specifications and having a UL 94 Flammability Classification of 94-5VA may be used.

The following T Ratings apply for the different types of pipe covering materials:

| Pipe Cover Type | T Rating (Hr) |
|-----------------|---------------|
| Fiberglass | 1 |
| Mineral Fiber | 1 |
| AB/PVC | 3/4 |

5. **Fill, Void or Cavity Material* - Sealant** - Min 3/4 in. (19 mm) thickness of fill material applied within annulus flush with top surface of floor or sole plate. Min 5/8 in. (16 mm) thickness of fill material applied within annulus on bottom surface of the ceiling or lower top plate of chase wall assembly. Additional fill material to be installed such that a min 1/8 in. (3.2 mm) bead is formed around the through penetrant on bottom surface of the ceiling or lower top plate of chase wall assembly.

SPECIFIED TECHNOLOGIES INC - SpecSeal Series SSS Sealant or SpecSeal LCI Sealant

*Bearing the UL Classification Marking

+Bearing the UL Recognized Component Mark



Specified Technologies Inc. 210 Evans Way Somerville, NJ 08876

Reproduced courtesy of Underwriters Laboratories, Inc.
Created or Revised: January 2, 2009

(800)992-1180 • (908)526-8000 • FAX (908)231-8415 • E-Mail:techserv@stifirestop.com • Website:www.stifirestop.com



F-C-5014
PAGE 2 OF 2