



## System No. HW-D-0136

Assembly Ratings-1 and 2 Hr (See Item 2)

Nominal Joint Width-1 in.

L Rating At Ambient - Less Than 1 CFM/Lin Ft

L Rating At 400°F - Less Than 1 CFM/Lin Ft

Class II Movement Capabilities-19% Compression and Extension

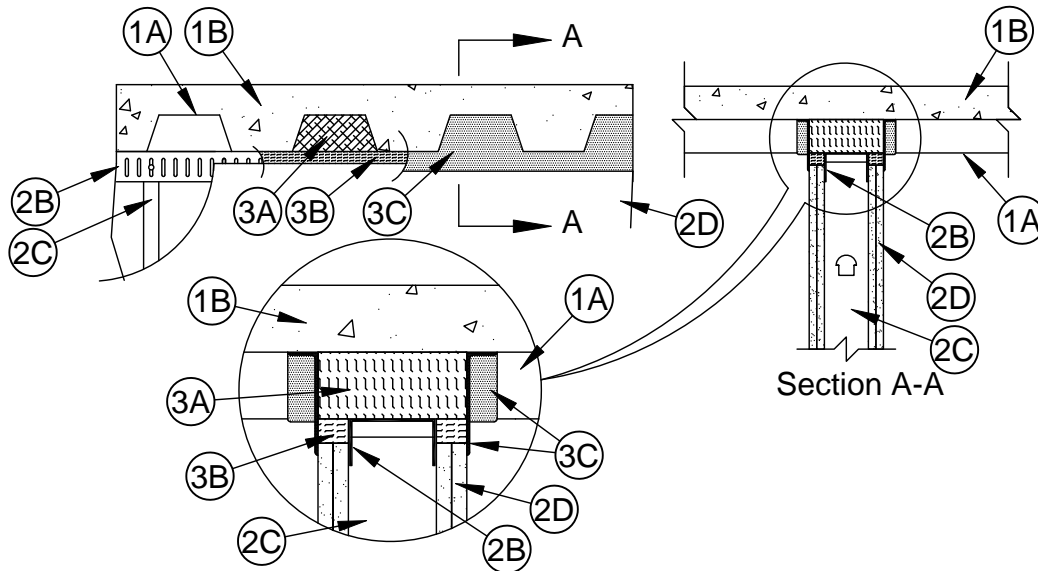

1. **Floor Assembly** - The fire-rated fluted steel deck/concrete floor assembly shall be constructed of the materials and in the manner described in the individual Floor-Ceiling Design in the UL Fire Resistance Directory and shall include the following construction features:
  - A. **Steel Floor and Form Units\*** - Max 3 in. (76 mm) deep galv steel fluted floor units.
  - B. **Concrete** - Min 2-1/2 in. (64 mm) thick reinforced concrete, as measured from the top plane of the floor units.
- 1A. **Roof Assembly** - (Not Shown) - As an alternate to the floor assembly (Item 1), a fire rated fluted steel deck roof assembly may be used. The roof assembly shall be constructed of the materials and in the manner described in the individual P900 Series Roof-Ceiling Design in the UL Fire Resistance Directory. The hourly fire rating of the roof assembly shall be equal to or greater than the hourly fire rating of the wall assembly. The roof assembly shall include the following construction features:
  - A. **Steel Roof Deck** - Max 3 in. (76 mm) deep galv steel fluted roof deck.
  - B. **Roof Insulation** - Min 2-1/4 in. (57 mm) thick poured insulating concrete, as measured from the top plane of the steel roof deck.
  - C. **Roof Covering\*** - Hot-mopped or cold-application materials compatible with insulating concrete.
2. **Wall Assembly** - The 1 or 2 hr fire-rated gypsum wallboard/stud wall assembly shall be constructed of the materials and in the manner described in the individual U400 Series Wall or Partition Design in the UL Fire Resistance Directory and shall include the following construction features:
  - A. **Floor Runners** - (Not Shown)-Floor runners of wall assembly shall consist of min No. 25 gauge galv steel channels sized to accommodate steel studs .



**Specified Technologies Inc. 210 Evans Way Somerville, NJ 08876**

Reproduced courtesy of Underwriters Laboratories, Inc.

Created or Revised: June 27, 2011

(800)992-1180 • (908)526-8000 • FAX (908)231-8415 • E-Mail:techserv@stifirestop.com • Website:www.stifirestop.com



HW-D-0136  
PAGE 1 OF 3

- B. **Light Gauge Framing\*-Slotted Ceiling Runner** - Ceiling runner to consist of galv steel channel with slotted flanges sized to accommodate steel studs . Ceiling runner installed perpendicular to direction of fluted steel floor or roof deck and secured to valleys with steel fasteners spaced max 24 in. (610 mm) OC.

**BRADY CONSTRUCTION INNOVATIONS INC,**

**DBA SLIPTRACK SYSTEMS - SLP-TRK**

**CALIFORNIA EXPANDED METAL PRODUCTS CO - CST**

**CLARKWESTERN BUILDING SYSTEMS INC - Type SLT, SLT-H**

**MARINO/WARE, DIV OF WARE INDUSTRIES**

**INC - Type SLT**

**METAL-LITE INC - The System**

**SCAFCO STEEL STUD MANUFACTURING CO**

**STEELER INC - Steeler Slotted Ceiling Runner**

**TELLING INDUSTRIES L L C - True-Action Deflection Track**

- C. **Studs** - Steel studs to be min 3-1/2 in. (89 mm) wide. Studs cut 3/4 to 1 in. (19 to 25 mm) less in length than assembly height with bottom nesting in and resting on floor runner and with top nesting in ceiling runner. Steel studs secured to slotted ceiling runner with No. 8 by 1/2 in. (13 mm) long wafer head steel screws at midheight of slot on each side of wall. Stud spacing not to exceed 24 in. (610 mm) OC.

- C1. **Light Gauge Framing\* -Slotted Studs** - Slotted steel stud to be used in conjunction with **Light Gauge Framing\* -Floor and Ceiling Runners** (Item 2B). Slotted steel studs to be min 3-1/2 in. (89 mm) wide. Slotted steel studs cut 1/2 in. to 3/4 in. (13 to 19 mm) less in length than assembly height with bottom nesting in and secured to both ceiling and floor runners. Ceiling runner secured to preformed slot within steel stud by means of No. 10 by 3/4 in. (19 mm) long low profile head steel screw. Floor runner attached to bottom of steel stud by means of No. 8 by 1/2 in. (13 mm) long pan head steel screw. Slotted steel stud spacing not to exceed 24 in. (610 mm) OC.

**STEELER INC - Steeler Slotted Stud**

- D. **Gypsum Board\*** - Gypsum board sheets installed to a min total 5/8 in. (16 mm) or 1-1/4 in. (32 mm) thickness on each side of wall for 1 and 2 hr fire rated assemblies, respectively. Wall to be constructed in the individual U400 Series Design in the UL Fire Resistance Directory, except that a max 1 in. (25 mm) gap shall be maintained between the top of the wallboard and the bottom surface of the steel floor or roof deck and the top row of screws shall be installed into the studs 3 to 3-1/2 in. (76 to 89 mm) below the valleys of the steel deck.

**The hourly fire rating of the joint system is equal to the hourly fire rating of the wall.**

3. **Joint System - Max separation between bottom of floor or roof deck and top of gypsum board (at time of installation of joint system) is 1 in. (25 mm). The joint system is designed to accommodate a max 18.75 percent compression or extension from it's installed width.** The joint system shall consist of forming and fill materials in the flutes of the steel floor or roof deck and between the top of the wallboard and bottom of the steel deck, as follows:

- A. **Forming Material\*** - Min 5-5/8 in. (143 mm) or 7 in. (178 mm) depth of 4 pcf (64 kg/m<sup>3</sup>) mineral wool batt insulation for 1 and 2 hr fire rated assemblies, respectively, cut to the shape of the fluted deck and installed into the flutes of the steel floor or roof deck between the top of the slotted ceiling runner and the steel deck. The mineral wool batt insulation is to be compressed min 14.3 percent in depth such that it is flush with the gypsum board surface on both sides of the wall.

**FIBREX INSULATIONS INC - FBX Safing Insulation**

**IIG MINWOOL L L C - MinWool-1200 Safing**

**ROCK WOOL MANUFACTURING CO - Delta Board**

**ROCKWOOL MALAYSIA SDN BHD - SAFE**

**ROXUL INC - SAFE**

**THERMAFIBER INC - Type SAF**



**Specified Technologies Inc. 210 Evans Way Somerville, NJ 08876**

Reproduced courtesy of Underwriters Laboratories, Inc.

Created or Revised: June 27, 2011

(800)992-1180 • (908)526-8000 • FAX (908)231-8415 • E-Mail:techserv@stifirestop.com • Website:www.stifirestop.com



HW-D-0136  
PAGE 2 OF 3

- A1. **Alternate Forming Material\*-Spray Applied Fire Resistive Material\*** - (Not Shown)-As an alternate to the mineral wool batt insulation (Item 3A), a min 4-7/8 in. (124 mm) or 6-1/8 in. (156 mm) depth of spray applied fire resistive material may be installed in the flutes of the steel floor or roof deck between the top of the slotted ceiling runner and the steel deck for the 1 and 2 hr fire ratings, respectively. The spray applied fire resistive material is to be finished flush with the valleys of the steel floor or roof deck and flush with the gypsum board surface on both sides of the wall to leave a nom 1 in. (25 mm) high gap above the top of the gypsum board. The spray applied fire resistive material is mixed with water in accordance with the mixing instructions on the bag.

**ISOLATEK INTERNATIONAL** - Type 300, Type II

When Type 300 material is used, the minimum average density of the material shall be 17.5 pcf (280 kg/m<sup>3</sup>) with a minimum individual density of 16 pcf (256 kg/m<sup>3</sup>). When Type II material is used, the minimum average density of the material shall be 13 pcf (208 kg/m<sup>3</sup>) with a minimum individual density of 11 pcf (176 kg/m<sup>3</sup>). See Design Information Section in Volume 1 of the Fire Resistance Directory for method of density determination.

**W R GRACE & CO - CONN** - MK-6/HY.

When MK-6/HY material is used, the minimum average density of the material shall be 15 pcf (240 kg/m<sup>3</sup>) with a minimum individual density of 14 pcf (224 kg/m<sup>3</sup>). See Design Information Section in Volume 1 of the Fire Resistance Directory for method of density determination.

- B. **Forming Material\*** - Min 5/8 in. (16 mm) or 1-1/4 in. (3.2 mm) wide sections of mineral wool batt insulation for 1 or 2 hr rated assemblies, respectively. Mineral wool batt insulation cut into strips, compressed 50 percent in thickness and installed cut edge first to completely fill the gap above the top of the gypsum board. The forming material shall be installed flush with both surfaces of wall.

**FIBREX INSULATIONS INC** - FBX Safing Insulation

**IIG MINWOOL L L C** - MinWool-1200 Safing

**ROCK WOOL MANUFACTURING CO** - Delta Board

**ROCKWOOL MALAYSIA SDN BHD** - SAFE

**ROXUL INC** - SAFE

**THERMAFIBER INC** - Type SAF

- C. **Fill, Void or Cavity Material\*-Sealant** - Min 1/8 in. (3.2 mm) wet thickness or 1/16 in. (1.6 mm) dry thickness of fill material spray applied to cover the forming material on each side of the wall in the flutes of the steel floor or roof deck and between the top of the wall and the bottom of the steel deck. Nom 1/8 in. (3.2 mm) wet thickness or 1/16 in. (1.6 mm) dry thickness of fill material shall overlap a min 1/2 in. (13 mm) onto gypsum board and onto the steel deck on both sides of wall.

**SPECIFIED TECHNOLOGIES INC** - SpecSeal AS200 Elastomeric Spray

\*Bearing the UL Classification Mark



**Specified Technologies Inc. 210 Evans Way Somerville, NJ 08876**

Reproduced courtesy of Underwriters Laboratories, Inc.  
Created or Revised: June 27, 2011

(800)992-1180 • (908)526-8000 • FAX (908)231-8415 • E-Mail:techserv@stifirestop.com • Website:www.stifirestop.com



HW-D-0136  
PAGE 3 OF 3