

## System No. HW-D-0252

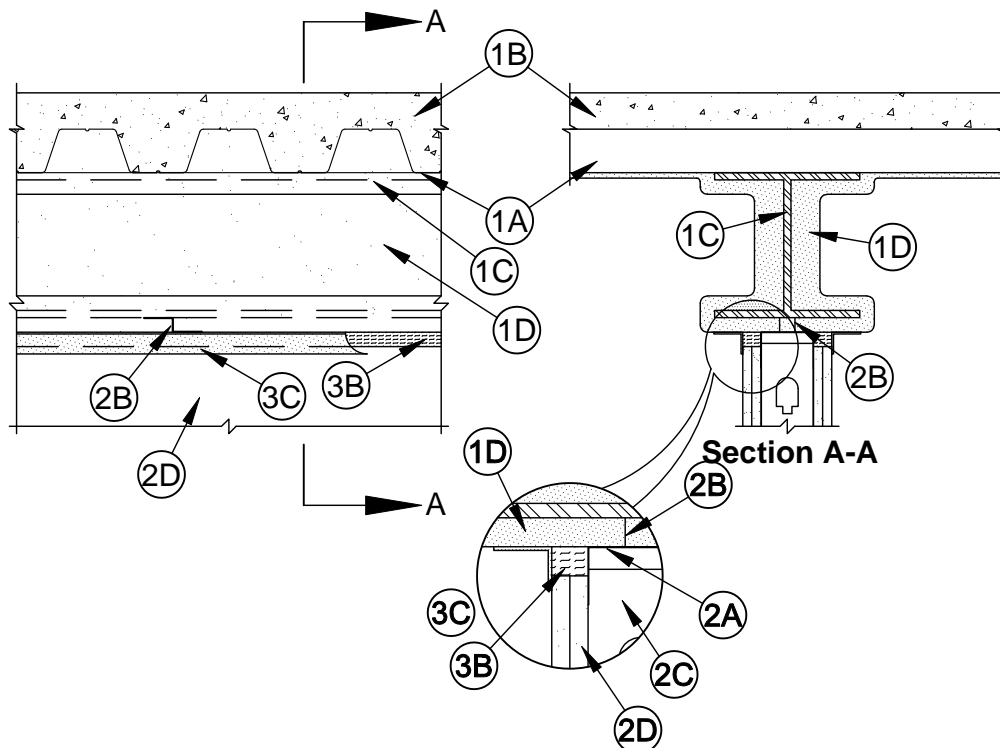

ANSI/UL2079	CAN/ULC S115
Assembly Ratings - 1 and 2 Hr (See Item 1)	F Ratings - 1 and 2 Hr (See Item 1)
Nominal Joint Width - 3/4 or 1-1/2 in. (See Item 3).	FT Ratings - 1 and 2 Hr (See Item 1)
Class II Movement Capabilities - 50% or 100 % Compression or Extension (See Item 3)	FH Ratings- 1 and 2 Hr (See Item 1)
L Rating At Ambient - Less Than 1 CFM/sq ft	FTH Ratings - 1 and 2 Hr (See Item 1)
L Rating At 400 F - Less Than 1 CFM/sq ft	Nominal Joint Width - 3/4 or 1-1/2 in. (See Item 3)
	Class II Movement Capabilities - 50% or 100 % Compression or Extension (See Item 3)
	L Rating At Ambient - Less Than 1 CFM/sq ft
	L Rating At 400 F - Less Than 1 CFM/sq ft



1. **Floor Assembly** - The fire-rated fluted steel deck/concrete floor assembly shall be constructed of the materials and in the manner described in the individual D700, D800, or D900 Series Floor-Ceiling Design in the UL Fire Resistance Directory and shall include the following construction features:
  - A. **Steel Floor And Floor Units\*** - Max 3 in. (76 mm) deep galv steel fluted floor units.
  - B. **Concrete** - Min 2-1/2 in. (64 mm) thick reinforced concrete, as measured from the top plane of the floor units.
  - C. **Structural Steel Support** - Steel beam, as specified in the individual D700, D800, or D900 Series Floor-Ceiling Design, used to support steel floor units. Steel beam centered over and parallel with wall assembly.



**Specified Technologies Inc. 210 Evans Way Somerville, NJ 08876**

Reproduced courtesy of Underwriters Laboratories, Inc.  
Created or Revised: November 10, 2011

(800)992-1180 • (908)526-8000 • FAX (908)231-8415 • E-Mail:techserv@stifirestop.com • Website:www.stifirestop.com



HW-D-0252  
PAGE 1 OF 3

- D. **Spray-Applied Fire Resistive Material\*** - After installation of the steel attachment clips (Item 2B), steel floor units and structural steel support to be sprayed with the min thickness of material specified in the individual D700, D800, or D900 Series Design. The flutes of the steel floor units are to be filled with material across the entire top flange of the steel beam. **Additional material shall be applied to the web of the steel beam on each side of the wall. For a 1 hr Assembly Rating, the thickness of material applied to each side of the steel beam web shall be 13/16 in. (21 mm). For a 2 hr Assembly Rating, the thickness of material applied to each side of the steel beam web shall be 1-3/8 in. (35 mm).**  
**SOUTHWEST FIREPROOFING PRODUCTS CO** - Type 5, Type 5GP  
**W R GRACE & CO - CONN** - Type MK-6/HY
- D1. **Spray-Applied Fire Resistive Material\*** - After installation of the steel attachment clips (Item 2B), steel floor units and structural steel support to be sprayed with the min thickness of material specified in the individual D700, D800, or D900 Series Design. The flutes of the steel floor units are to be filled with material across the entire top flange of the steel beam. **Additional material shall be applied to the web of the steel beam on each side of the wall. For a 1 hr Assembly Rating, the thickness of material applied to each side of the steel beam web shall be 11/16 in. (18 mm). For a 2 hr Assembly Rating, the thickness of material applied to each side of the steel beam web shall be 1-1/2 in. (38 mm).**  
**ISOLATEK INTERNATIONAL** - Type 300 or Type II
2. **Wall Assembly** - The 1 or 2 hr fire-rated gypsum board/stud wall assembly shall be constructed of the materials and in the manner described in the individual U400, V400 or W400 Series Wall and Partition Design in the UL Fire Resistance Directory and shall include the following construction features:
- A. **Steel Floor and Ceiling Runners** - Floor and ceiling runners of wall assembly shall consist of galv steel channels sized to accommodate steel studs (Item 2B). Ceiling runner to be provided with min 1-1/4 in. (32 mm) to max 2 in. (51 mm) flanges. When deflection channel (Item 3A) is used, flange height of ceiling runner is to be equal to or greater than flange height of deflection channel and the ceiling runner is to nest within the deflection channel with a 1/2 in. (13 mm) to 3/4 in. (19 mm) gap maintained between the top of the ceiling runner and the top of the deflection channel. When deflection channel is not used, flange height of ceiling runner shall be min 1/4 in. (6 mm) greater than max extended joint width and ceiling runner is secured to steel beam (Item 1A) with steel attachment clips (Item 2B) spaced max 24 in. (610 mm) OC. Ceiling runner or deflection channel to be centered beneath and parallel with bottom flange of steel beam. A clearance equal to the required thickness of spray-applied fireproofing material (Item 1D) shall be maintained between the top of the ceiling runner or deflection channel and the bottom flange of the steel beam.
- A1. **Light Gauge Framing\* - Slotted Ceiling Runner** - Slotted ceiling runner may be used as an alternate to the ceiling runner in Item 2A. Slotted ceiling runner to consist of galv steel channel with slotted flanges sized to accommodate steel studs (Item 2C). Ceiling runner is secured to steel beam (Item 1A) with steel attachment clips (Item 2B) spaced max 24 in. (610 mm) OC. Slotted ceiling runner to be centered beneath and parallel with bottom flange of steel beam. A clearance equal to the required thickness of spray-applied fireproofing material (Item 1D) shall be maintained between the top of the slotted ceiling runner and the bottom flange of the steel beam. When slotted ceiling runner is used, deflection channel (Item 3A) shall not be used.
- BRADY CONSTRUCTION INNOVATIONS INC,**  
**DBA SLIPTRACK SYSTEMS** - SLP-TRK, SLPTRK325  
**CALIFORNIA EXPANDED METAL PRODUCTS CO** - CST  
**CLARKDIETRICH BUILDING SYSTEMS** - Type SLT, SLT-H  
**MARINO/WARE, DIV OF WARE INDUSTRIES**  
**INC** - Type SLT  
**METAL-LITE INC** - The System  
**THE STEEL NETWORK INC** - VertiTrack VT, series,250VT, 362VT, 400VT, 600VT and 800VT
- B. **Steel Attachment Clips** - Z-shaped clips formed from 1 in. (25 mm) wide strips of min 20 ga galv steel. Clips to be sized to extend through the thickness of the spray-applied fire-resistive material on the bottom flange of the steel beam with 2 in. (51 mm) long upper and lower legs. Legs of clips fastened to bottom of beam (prior to application of spray-applied fire-resistive materials) and top of ceiling runner (or deflection channel) with steel fasteners or welds. Clips spaced max 16 in. (406 mm) OC.



**Specified Technologies Inc. 210 Evans Way Somerville, NJ 08876**

Reproduced courtesy of Underwriters Laboratories, Inc.  
 Created or Revised: November 10, 2011

(800)992-1180 • (908)526-8000 • FAX (908)231-8415 • E-Mail:techserv@stifirestop.com • Website:www.stifirestop.com



HW-D-0252  
 PAGE 2 OF 3

- C. **Studs** - Steel studs to be min 3-1/2 in. (89 mm) wide. Studs cut 1/2 in. (13 mm) to 1-1/4 in. (32 mm) less in length than assembly height with bottom nesting in and secured to floor runner. When deflection channel (Item 3A) is used, steel studs attached to ceiling runner (Item 2A) with sheet metal screws located 1/2 in. (13 mm) below the bottom of the deflection channel. When deflection channel is not used, studs to nest in ceiling runner without attachment.
- D. **Gypsum Board\*** - Gypsum board sheets installed to a min total 5/8 in. (16 mm) or 1-1/4 in. (32 mm) thickness on each side of wall for 1 and 2 hr fire rated assemblies, respectively. Wall to be constructed in accordance with the individual U400 or V400 Series Design in the UL Fire Resistance Directory, except that a max 1 in. (25 mm) high gap shall be maintained between the top of the gypsum board and the bottom plane of the spray applied fire resistive material on the structural steel support member. The screws attaching the gypsum board to the studs along the top of the wall shall be located 1 in. (25 mm) below the bottom of the ceiling runner. No gypsum board attachment screws shall be driven into the ceiling runner or into the optional deflection channel.

**The hourly fire rating of the joint system is equal to the hourly fire rating of the wall.**

- 3. **Joint System - Max separation between spray applied fire resistive material on bottom of structural support member and top of gypsum board (at time of installation of joint system) is 3/4 or 1-1/2 in. (19 or 38 mm). The joint system is designed to accommodate a max 50 or 100 percent compression or extension from its installed width as measured between bottom plane of the protective material on the steel beam and the top of the gypsum board. When Item 3B1 is used in lieu of the strips of mineral wool described in Item 3B, the maximum joint width is 3/4 in. (19 mm) and the movement capabilities are 100% compression or extension.** The joint system shall consist of forming and fill materials, with or without a deflection channel (Item 3A), as follows:

- A. **Deflection Channel** - (Optional, Not Shown) - Max 2 in. (51 mm) deep min 24 gauge galv steel channel sized to accommodate ceiling runner (Item 2A). Deflection channel installed parallel with and centered beneath bottom flange of steel beam (Item 1C) and secured to steel beam with steel clips (Item 2B) spaced max 16 in. (406 mm) OC. The ceiling runner (Item 2A) is installed within the deflection channel to maintain a 1/2 in. (13 mm) to 3/4 in. (19 mm) gap between the top of the ceiling runner and the top of the deflection channel. A clearance equal to the required thickness of spray-applied fireproofing material (Item 1D) shall be maintained between the top of the ceiling runner or deflection channel and the bottom flange of the steel beam. The ceiling runner nests inside the deflection channel without attachment.
- B. **Forming Material\*** - Sections of nom 4 pcf (64 kg/m<sup>3</sup>) mineral wool batt insulation to be compressed 50 percent in thickness and installed cut edge first to completely fill the gap above the top of the gypsum board. The forming material shall be installed flush with both surfaces of wall.

**IIG MINWOOL L L C** - MinWool-1200 Safing

**ROCK WOOL MANUFACTURING CO** - Delta Board

**ROCKWOOL MALAYSIA SDN BHD** - SAFE

**ROXUL INC** - SAFE

**THERMAFIBER INC** - Type SAF

- B1. **Forming Material\*** - (Not Shown) - As an option to Item 3B, nom 3/16 in. (4.8 mm) thick by 4 in. (102 mm) high joint forming material profile installed on both sides of the wall assembly. Profile installed by first marking a line across the top of the wall 3 in. (76 mm) below the bottom plane of the steel floor or roof deck valleys. Joint profile material positioned with its top edge against both the underside of the spray-applied fire-resistive material with its bottom edge on the line scribed on the wall assembly. Bottom of the joint profile attached to gypsum board with nom 1/2 in. (13 mm) long steel staples spaced not greater than 8 in. (203 mm) OC. Adjoining lengths of profile to overlap approx 3/4 in. (19 mm) at shiplapped ends.

**SPECIFIED TECHNOLOGIES INC** - SpecSeal Speed Flex Joint Profile

- C. **Fill, Void or Cavity Material\* - Sealant** - Min 1/8 in. (3.2 mm) wet thickness or 1/16 in. (1.6 mm) dry thickness of fill material spray applied over the forming material on each side of the wall. Fill material to overlap min 1/2 in. (13 mm) onto gypsum board and min 2 in. onto the spray applied material (Item 1D) on the steel beam on both sides of wall.

**SPECIFIED TECHNOLOGIES INC** - SpecSeal AS200 Elastomeric Spray

\*Bearing the UL Classification Mark



**Specified Technologies Inc. 210 Evans Way Somerville, NJ 08876**

Reproduced courtesy of Underwriters Laboratories, Inc.

Created or Revised: November 10, 2011

(800)992-1180 • (908)526-8000 • FAX (908)231-8415 • E-Mail:techserv@stifirestop.com • Website:www.stifirestop.com



HW-D-0252  
PAGE 3 OF 3