

System No. HW-D-0456

Assembly Ratings - 1 and 2 Hr (See Items 1 and 4C)

Nominal Joint Width - 3/4 or 1 In. (See Item 5)

L Rating At Ambient - Less Than 1 CFM/Lin Ft

L Rating At 400°F - Less Than 1 CFM/Lin Ft

Class II Movement Capabilities - 19% or 100% Compression or Extension (See Item 5)

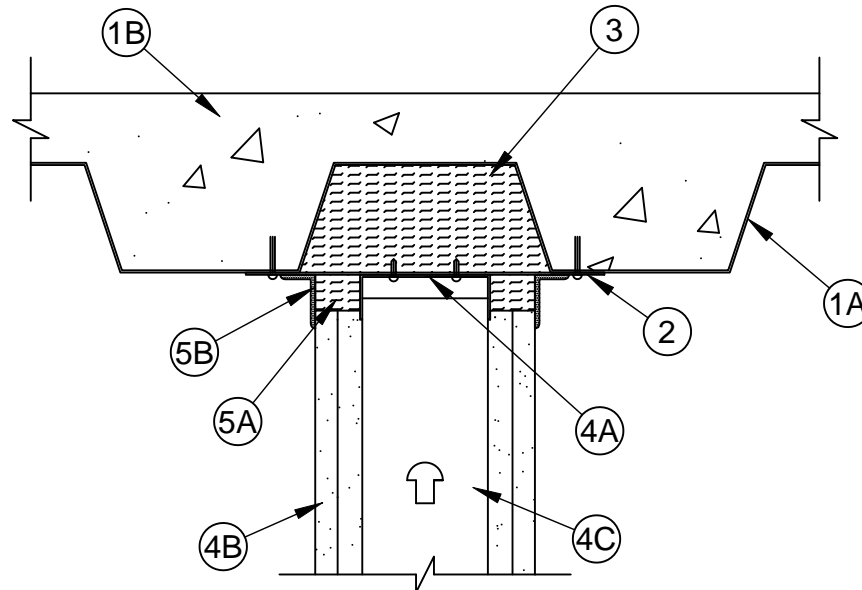

1. **Floor Assembly** - The fire-rated fluted steel floor unit/concrete floor assembly shall be constructed of the materials and in the manner described in the individual Floor-Ceiling Design in the Fire Resistance Directory and shall include the following construction features:
 - A. **Steel Floor and Form Units*** - Max 3 in. (76 mm) deep galv steel fluted floor units.
 - B. **Concrete** - Min 2-1/2 in. (64 mm) thick reinforced concrete, as measured from the top plane of the floor units.
- 1A. **Roof Assembly** - (Not Shown) - As an alternate to the floor assembly (Item 1), a fire rated fluted steel deck roof assembly may be used. The roof assembly shall be constructed of the materials and in the manner described in the individual P900 Series Roof-Ceiling Design in the UL Fire Resistance Directory. The hourly fire rating of the roof assembly shall be equal to or greater than the hourly fire rating of the wall assembly. The roof assembly shall include the following construction features:
 - A. **Steel Roof Deck** - Max 3 in. (76 mm) deep galv steel fluted roof deck.
 - B. **Roof Insulation** - Min 2-1/4 in. (57 mm) thick poured insulating concrete, as measured from the top plane of the steel roof deck.
 - C. **Roof Covering*** - Hot mopped or cold-application materials compatible with insulating concrete.
2. **Steel Straps** - Min 2 in. (51 mm) wide 16 MSG (0.059 in. or 1.5 mm thick) galv steel straps cut to a length to span the flute and to overlap min 1-1/2 in. (38 mm) on the adjacent valleys of fluted floor units. Straps spaced max 24 in. (610 mm) OC and fastened to floor assembly with 1/4 in. (6 mm) diam by 1-1/2 in. (38 mm) long steel concrete anchors.
3. **Forming Material*** - Mineral wool batt insulation, nom 4 pcf (64 kg/m³), cut to the shape of the fluted floor units, friction fit to completely fill the flutes above the steel straps. Adjacent lengths of batts to be tightly butted with butted seams spaced min 24 in. (610 mm) apart along the length of the plugs.

FIBREX INSULATIONS INC - FBX Safing Insulation

IIG MINWOOL L L C - MinWool-1200 Safing

ROCK WOOL MANUFACTURING CO - Delta Board

ROXUL ASIA SDN BHD - Safe

ROXUL INC - Safe

THERMAFIBER INC - Type SAF



Specified Technologies Inc. 210 Evans Way Somerville, NJ 08876

Reproduced courtesy of Underwriters Laboratories, Inc.

Created or Revised: March 19, 2010

(800)992-1180 • (908)526-8000 • FAX (908)231-8415 • E-Mail:techserv@stifirestop.com • Website:www.stifirestop.com



HW-D-0456
PAGE 1 OF 3

4. **Wall Assembly** - The 1 or 2 h fire rated gypsum board/stud wall assembly shall be constructed of the materials and in the manner specified in the individual U400 or V400 Series Wall and Partition Design in the UL Fire Resistance Directory and shall include the following construction features:
- A. **Steel Floor and Ceiling Runners** - Floor and ceiling runners of wall assembly shall consist of galv steel channels sized to accommodate steel studs. Ceiling runner to be provided with min 1-1/4 in. (32 mm) to max 3 in. (76 mm) flanges. Ceiling runner installed parallel to direction of fluted steel floor units, directly beneath steel straps, and secured to straps with two No. 8 self-drilling, self-tapping steel screws per strap.
 - A1. **Light Gauge Framing* - Slotted Ceiling Runner** - As an alternate to the ceiling runner in Item 2A, slotted ceiling runner consisting of galv steel channel with slotted flanges sized to accommodate steel studs (Item 2B). Ceiling runner installed parallel to direction of fluted steel floor units, directly beneath steel straps, and secured to straps with two No. 8 self-drilling, self-tapping steel screws per strap.

BRADY CONSTRUCTION INNOVATIONS INC,

DBA SLIPTRACK SYSTEMS - SLP-TRK

CALIFORNIA EXPANDED METAL PRODUCTS CO - CST

CLARKWESTERN BUILDING SYSTEMS INC - Type SLT, SLT-H

METAL-LITE INC - The System

STEELER INC - Steeler Slotted Ceiling Runner

- B. **Studs** - Steel studs to be min 2-1/2 in. (64 mm) wide. Studs cut 1/2 in. to 3/4 in. (13 to 19 mm) less in length than assembly height with bottom nesting in and resting on the floor runner and with top nesting in ceiling runner without attachment. When slotted ceiling runner (Item 4A1) is used, steel studs secured to slotted ceiling runner with No. 8 by 1/2 in. (13 mm) long wafer head steel screws at midheight of slot on each side of wall. Stud spacing not to exceed 24 in. (610 mm) OC.
- B1. **Light Gauge Framing* -Slotted Studs** - Slotted steel stud to be used in conjunction with **Light Gauge Framing* -Floor and Ceiling Runners** (Item 4A1). Slotted steel studs to be min 2-1/2 in. (64mm) wide. Slotted steel studs cut 1/2 in. to 3/4 in. (13 to 19 mm) less in length than assembly height with bottom nesting in and secured to both ceiling and floor runners. Ceiling runner secured to preformed slot within steel stud by means of No. 10 by 3/4 in. (19 mm) long low profile head steel screw. Floor runner attached to bottom of steel stud by means of No. 8 by 1/2 in. (13 mm) long pan head steel screw. Slotted steel stud spacing not to exceed 24 in. (610 mm) OC.

STEELER INC - Steeler Slotted Stud

- C. **Gypsum Board*** - Gypsum board sheets installed to a min total 5/8 in. (16 mm) or 1-1/4 in. (31 mm) thickness on each side of wall for 1 and 2 hr rated assemblies, respectively. Wall to be constructed as specified in the individual U400 or V400 Series Design in the UL Fire Resistance Directory, except that a max 1 in. (25 mm) gap shall be maintained between the top of the gypsum board and the underside of the steel floor or roof deck. The screws attaching the gypsum board to the studs along the top of the wall shall be located 1 in. (25 mm) below the bottom of the ceiling runner. No gypsum board attachment screws shall be driven into the ceiling runner.

5. **Joint System** - Max separation between bottom of floor and top of gypsum board is 3/4 or 1 in. (19 or 25 mm). The joint system is designed to accommodate a max 19 or 100 percent compression or extension from its installed width. **When Item 5A1 is used in lieu of the strips of mineral wool described in Item 5A, the maximum joint width is 3/4 in. (19 mm) and the movement capabilities are 100% compression or extension.** The joint system consists of a forming material and a fill material between the top of the gypsum board and the bottom of the floor, as follows:

- A. **Forming Material*** - Min 4 pcf (64 kg/m³) density mineral wool batt insulation cut into strips to fill the gap between the top of gypsum board and bottom of the floor units. The width of the strips shall be equal to the total thickness of the gypsum board. The strips of mineral wool are compressed 50 percent in thickness and firmly packed into the gap between the top of the gypsum board and bottom of the mineral wool batt sections or steel floor units.

FIBREX INSULATIONS INC - FBX Safing Insulation

IIG MINWOOL L L C - MinWool-1200 Safing

ROCK WOOL MANUFACTURING CO - Delta Board

ROXUL ASIA SDN BHD - Safe

ROXUL INC - Safe

THERMAFIBER INC - Type SAF



Specified Technologies Inc. 210 Evans Way Somerville, NJ 08876

Reproduced courtesy of Underwriters Laboratories, Inc.

Created or Revised: March 19, 2010

(800)992-1180 • (908)526-8000 • FAX (908)231-8415 • E-Mail:techserv@stifirestop.com • Website:www.stifirestop.com



HW-D-0456
PAGE 2 OF 3

A1. **Forming Material*** - (Not Shown) - As an option to Item 5A, nom 3/16 in. (4.8 mm) thick by 4 in. (102 mm) high joint forming material profile installed on both sides of the wall assembly. Profile installed by first marking a line across the top of the wall 3 in. (76 mm) below the bottom plane of the steel floor or roof deck valleys. Joint profile material positioned with its top edge against the underside of the floor and with its bottom edge on the line scribed on the wall assembly. Bottom of the joint profile attached to gypsum board with nom 1/2 in. (13 mm) long steel staples spaced not greater than 8 in. (203 mm) OC. Adjoining lengths of profile to overlap approx 3/4 in. (19 mm) at shiplapped ends.

SPECIFIED TECHNOLOGIES INC - SpecSeal Speed Flex Joint Profile

B. **Fill, Void or Cavity Material* - Sealant** - Min 1/8 in. (3.2 mm) wet thickness (min 1/16 in. or 1.6 mm dry thickness) applied to cover forming material (Item 3A) with a min 1/2 in. (13 mm) overlap onto the gypsum board, steel strapping and steel deck on both sides of wall.

SPECIFIED TECHNOLOGIES INC - SpecSeal AS200 Elastomeric Spray

*Bearing the UL Classification Mark



Specified Technologies Inc. 210 Evans Way Somerville, NJ 08876

Reproduced courtesy of Underwriters Laboratories, Inc.

Created or Revised: March 19, 2010

(800)992-1180 • (908)526-8000 • FAX (908)231-8415 • E-Mail:techserv@stifirestop.com • Website:www.stifirestop.com



HW-D-0456
PAGE 3 OF 3