

System No. HW-D-0617

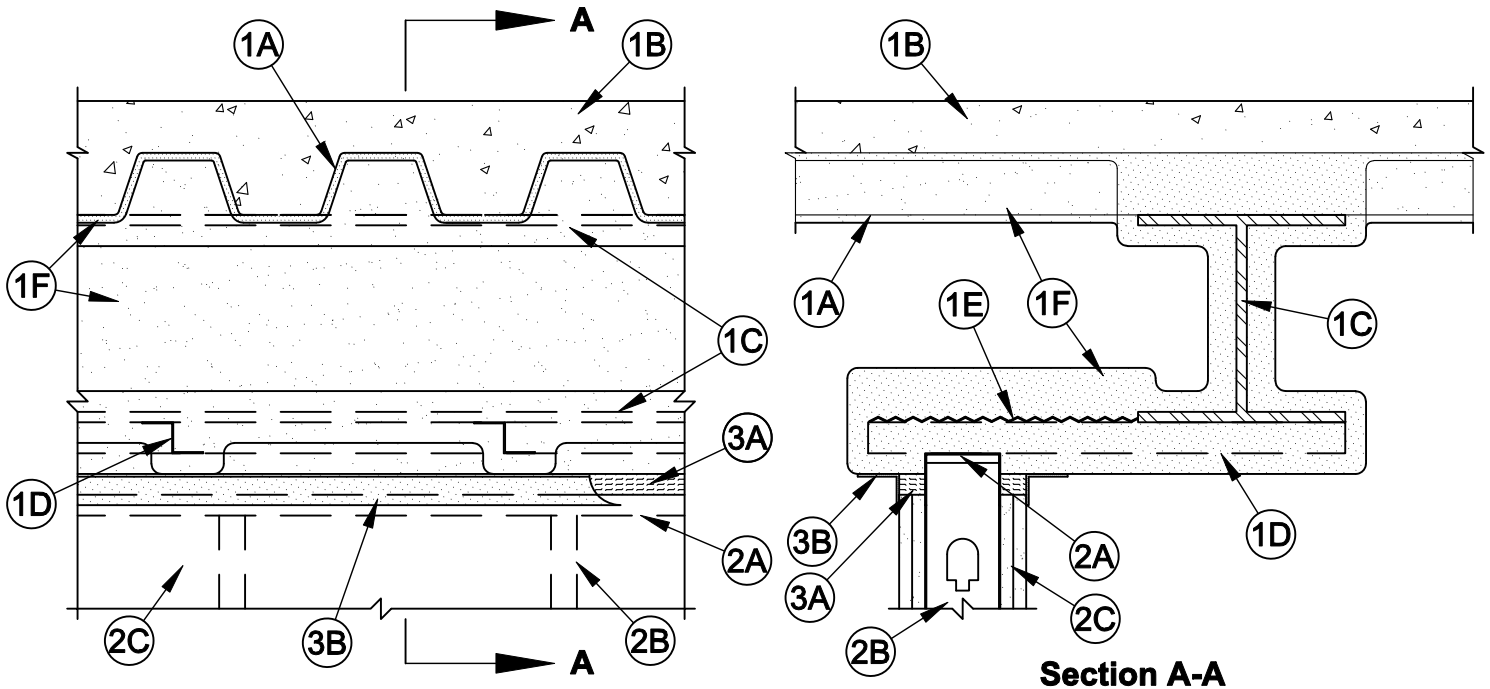

ANSI/UL2079	CAN/ULC S115
Assembly Ratings - 1 and 2 Hr (See Items 1 and 2)	F Ratings - 1 and 2 Hr (See Items 1 and 2)
Maximum Joint Width - 3/4 or 1-1/2 In. (See Item 3)	FT Ratings - 1 and 2 Hr (See Items 1 and 2)
Class II or III Movement Capabilities - 25%, 50% or 100% Compression or Extension (See Item 3)	FH Ratings - 1 and 2 Hr (See Items 1 and 2)
L Rating At Ambient - Less Than 1 CFM/sq ft	FTH Ratings - 1 and 2 Hr (See Items 1 and 2)
L Rating At 400 F - Less Than 1 CFM/sq ft	Maximum Joint Width - 3/4 or 1-1/2 In. (See Item 3)
	Class II or III Movement Capabilities - 25%, 50% or 100% Compression or Extension (See Item 3)
	L Rating At Ambient - Less Than 1 CFM/sq ft
	L Rating At 400 F - Less Than 1 CFM/sq ft



1. **Floor Assembly** - The fire-rated fluted steel deck/concrete floor assembly shall be constructed of the materials and in the manner described in the individual D700 or D900 Series Floor-Ceiling Design in the UL Fire Resistance Directory and shall include the following construction features:
 - A. **Steel Floor And Floor Units*** - Max 3 in. (76 mm) deep galv steel fluted floor units.
 - B. **Concrete** - Min 2-1/2 in. (64 mm) thick reinforced lightweight or normal weight (100-150 pcf or 1600-2400 kg/m3) concrete, as measured from the top plane of the floor units.
 - C. **Structural Steel Support** - Steel beam, as specified in the individual D700 or D900 Series Floor-Ceiling Design, used to support steel floor units. Steel beam parallel with wall assembly and 8 in. (203 mm) max from wall assembly.
 - D. **Steel Attachment Clips** - Z-shaped bars or channels, located to span from steel beam to min 1 in. (25 mm) beyond face of wall and spaced max 24 in. (610 mm) on center. Z-shaped bars are nom 1-1/2 to 2 in. (38 to 51 mm) deep and formed from min 16 gauge painted or galvanized steel. Channels are nom 1-1/2 in. (38 mm) or 2 in. (51 mm) deep and formed from min 16 gauge painted or galvanized steel. Each bar or channel welded to steel beam and welded, bolted or screwed to ceiling runner of wall. Each bar or channel shall be fully covered with spray applied fire resistive material (Item 1F) to the minimum thickness of material required on the flanges of the steel beam.



Specified Technologies Inc. 210 Evans Way Somerville, NJ 08876

Reproduced courtesy of Underwriters Laboratories, Inc.
Created or Revised: November 10, 2011



- E. **Steel Lath** - Nom 3/8 in. (10 mm) diamond mesh expanded steel rib lath having a nom weight of 3.4 lb/yd² (1.8 kg/m²) shall be installed over and attached to the steel attachment clip bars or channels (Item 1D) to completely cover the exposed area from the flange tip of the steel beam to the end of the bar/channel framing extending beyond the wall surface. The lath shall be secured with steel fasteners or tie wire and shall be fully covered with spray applied fire resistive material (Item 1F).
- F. **Spray-Applied Fire Resistive Material*** - After installation of steel attachment clip and steel lath (Items 1D and 1E), steel floor units and structural steel support to be sprayed with the min thickness of material specified in the individual D700 or D900 Series Design. The flutes of the steel floor units are to be filled with material across the entire top flange of the steel beam. Each bar or channel attachment clip member (Item 1D) shall be fully covered with spray applied fire resistive material to the minimum thickness of material required on the flanges of the steel beam. The thickness of material applied to the expanded steel lath shall be sufficient to completely fill the spaces between the bar/channel attachment clip above the wall. Additional material shall be applied to the web of the steel beam on each side of the wall. The min total thickness of material applied to each side of the steel beam web shall be 13/16 in. (21 mm) for 1 hr fire rated assemblies and 1 3/8 in. (35 mm) for 2 hr fire rated assemblies. For D700 Series Designs, all surfaces of the steel floor units to be sprayed with the thickness of material specified in the individual D700 Series Design. For D900 Series Designs structural steel supports, steel attachment clip and steel lath only to be sprayed in accordance with the specifications in the individual D900 Series Design.

W R GRACE & CO - CONN - Type MK-6/HY, MK-6/HYES, MK-65 and RG

ISOLATEK INTERNATIONAL - Type 300 or Type II

SOUTHWEST FIREPROOFING PRODUCTS CO - Type 5, Type 5GP

The hourly fire rating of the floor assembly shall be equal to or greater than the hourly fire rating of the wall assembly.

- 1A. **Roof Assembly** - (Not Shown) - As an alternate to the floor assembly, a fire-rated fluted steel deck roof assembly may be used. The roof assembly shall be constructed of the materials and in the manner described in the individual P900 or P700 Series Roof-Ceiling Design in the UL Fire Resistance Directory. The roof assembly shall include the following construction features:
 - A. **Steel Roof Deck** - Max 3 in. (76 mm) deep galv steel fluted roof deck.
 - B. **Roof Insulation** - For P900 Series Designs, min 2-1/4 in. (57 mm) thick poured insulating concrete, as measured from the top roof deck. For P700 Series Designs, roof insulation shall be as specified in the individual design.
 - C. **Structural Steel Support** - Steel beam, as specified in the individual P700 or P900 Series Floor-Ceiling Design, used to support steel floor units. Steel beam parallel with wall assembly and 8 in. (203 mm) max from wall assembly.
 - D. **Steel Attachment Clips** - Z-shaped bars or channels, located to span from steel beam to min 1 in. (25 mm) beyond face of wall and spaced max 24 in. (610 mm) on center. Z-shaped bars are nom 1-1/2 to 2 in. (38 to 51 mm) deep and formed from min 16 gauge painted or galvanized steel. Channels are nom 1-1/2 in. (38 mm) or 2 in. (51 mm) deep and formed from min 16 gauge painted or galvanized steel. Each bar or channel welded to steel beam and welded, bolted or screwed to ceiling runner of wall. Each bar or channel shall be fully covered with spray applied fire resistive material to the minimum thickness of material required on the flanges of the steel beam.
 - E. **Steel Lath** - Nom 3/8 in. (10 mm) diamond mesh expanded steel rib lath having a nom weight of 3.4 lb/yd² (1.8 kg/m²) shall be installed over and attached to the steel attachment clip bars or channels (Item 1AD) to completely cover the exposed area from the flange tip of the steel beam to the end of the bar/channel framing extending beyond the wall surface. The lath shall be secured with steel fasteners or tie wire and shall be fully covered with spray applied fire resistive material (Item 1AF).



Specified Technologies Inc. 210 Evans Way Somerville, NJ 08876

Reproduced courtesy of Underwriters Laboratories, Inc.
Created or Revised: November 10, 2011

(800)992-1180 • (908)526-8000 • FAX (908)231-8415 • E-Mail:techserv@stifirestop.com • Website:www.stifirestop.com



HW-D-0617
PAGE 2 OF 4

- F. **Spray-Applied Fire Resistive Material*** - After installation of steel attachment clip and steel lath (Items 1AD and 1AE) surfaces of the roof deck to be sprayed with the thickness of material specified in the individual P700 Series Design. For P900 Series Designs structural steel supports, steel attachment clip and steel lath only to be sprayed in accordance with the specifications in the individual P900 Series Design. The flutes of the steel roof deck are to be filled with material across the entire top flange of the steel beam. Each bar or channel attachment clips (Item 1AD) shall be fully covered with spray applied fire resistive material to the minimum thickness of material required on the flanges of the steel beam. The thickness of material applied to the expanded steel lath shall be sufficient to completely fill the spaces between the bar/channel attachment clip above the wall. Additional material shall be applied to the web of the steel beam on each side of the wall. The min total thickness of material applied to each side of the steel beam web shall be 13/16 in. (21 mm) for 1 hr fire rated assemblies and 1-3/8 in. (35 mm) for 2 hr fire rated assemblies.

W R GRACE & CO - CONN - Type MK-6/HY, MK-6/HYES, MK-65 and RG

ISOLATEK INTERNATIONAL - Type 300 or Type II

SOUTHWEST FIREPROOFING PRODUCTS CO - Type 5, Type 5GP

The hourly fire rating of the roof assembly shall be equal or greater than the hourly fire rating of the wall assembly.

2. **Wall Assembly** - The 1 or 2 hr fire rated gypsum board/steel stud wall assembly shall be constructed of the materials and in the manner described in the individual U400, V400 or W400 Series Wall and Partition Design in the UL Fire Resistance Directory and shall include the following construction features:

- A. **Steel Floor and Ceiling Runners** - Floor and ceiling runners of wall assembly shall consist of galv steel channels sized to accommodate steel studs (Item 2B). Ceiling runner to be provided with min 1-1/4 in. (32 mm) to max 3 in. (76 mm) flanges. Flange height of ceiling runner shall be min 1/4 in. (6 mm) greater than max extended joint width. Ceiling runner is secured to steel attachment clip (Item 1D) with steel fasteners or welds spaced max 24 in. (610 mm) OC. Ceiling runner to be installed parallel with structural steel support and located such that a max clearance of 8 in. (203 mm) is present between the finished wall and the flange of the steel beam (Item 1C).

- A1. **Light Gauge Framing* - Slotted Ceiling Runner** - Slotted ceiling runner may be used as an alternate to the ceiling runner in Item 2A. Slotted ceiling runner to consist of galv steel channel with slotted flanges sized to accommodate steel studs (Item 2B). Ceiling runner installed perpendicular to direction of fluted steel floor or roof deck and secured to valleys with steel masonry anchors spaced max 24 in. (610 mm) OC.

BRADY CONSTRUCTION INNOVATIONS INC,

DBA SLIPTRACK SYSTEMS - SLP-TRK, SLPTRK325

- B. **Studs** - Steel studs to be min 3-1/2 in. (89 mm) wide. Studs cut 1/2 in. to 1-1/4 in. (13 to 32 mm) less in length than assembly height with bottom nesting in and secured to floor runner. Studs to nest in ceiling runner without attachment.
- C. **Gypsum Board*** - Gypsum board sheets installed to a min total 5/8 in. (16 mm) or 1-1/4 in. (32 mm) thickness on each side of wall for 1 and 2 hr fire rated assemblies, respectively. Wall to be constructed as specified in the individual U400, V400 or W400 Series Design in the UL Fire Resistance Directory except that a max 1-1/2 in. (38 mm) gap shall be maintained between the top of the gypsum board and the bottom plane of the spray applied fire resistive material on the steel attachment clip (Item 1D) on both sides of the wall assembly.

The hourly fire rating of the joint system is equal to the hourly fire rating of the wall.

3. **Joint System** - Max separation between bottom plane of spray-applied fire resistive material on the steel attachment clip (Item 1D) and the top of the gypsum board is 3/4 or 1-1/2 in. (19 or 38 mm). When Item 3A1 is used in lieu of the mineral wool strips described in Item 3A, the maximum joint width is 3/4 in. (19 mm) and the movement capability of the joint system is 100 percent compression or extension. Otherwise, the movement capability of the joint system is 50 percent compression or extension when spray sealant (Item 3B) is used or 25 percent compression only when sealant (Item 3C) is used. The joint system shall consist of forming and fill materials, as follows:



Specified Technologies Inc. 210 Evans Way Somerville, NJ 08876

Reproduced courtesy of Underwriters Laboratories, Inc.

Created or Revised: November 10, 2011

(800)992-1180 • (908)526-8000 • FAX (908)231-8415 • E-Mail:techserv@stifirestop.com • Website:www.stifirestop.com



HW-D-0617
PAGE 3 OF 4

- A. **Forming Material*** - Nom 4 pcf (64 kg/m³) density mineral wool batt insulation. Sections of mineral wool batt cut to a thickness equal to the overall thickness of gypsum board and compressed a min of 50 percent into the gap between the top of the gypsum board and the bottom plane of the spray applied fire resistive material on the steel attachment clip (Item 1D) on both sides of the wall assembly.

IIG MINWOOL L L C - MinWool-1200 Safing

ROCK WOOL MANUFACTURING CO - Delta Safing Insulation

ROCKWOOL MALAYSIA SDN BHD - SAF Mineral Wool

ROXUL INC - SAF Mineral Wool

THERMAFIBER INC - Type SAF

- A1. **Forming Material*** - (Not Shown) - As an option to Item 3A, nom 3/16 in. (4.8 mm) thick by 4 in. (102 mm) high joint forming material profile installed on both sides of the wall assembly. Profile installed by first marking a line across the top of the wall 3 in. (76 mm) below the bottom plane of the steel floor or roof deck valleys. Joint profile material positioned with its top edge against both the underside of the spray-applied fire-resistive material with its bottom edge on the line scribed on the wall assembly. Bottom of the joint profile attached to gypsum board with nom 1/2 in. (13 mm) long steel staples spaced not greater than 8 in. (203 mm) OC. Adjoining lengths of profile to overlap approx 3/4 in. (19 mm) at rabbeted ends.

SPECIFIED TECHNOLOGIES INC - SpecSeal Speed Flex Joint Profile

- B. **Fill, Void or Cavity Material* - Sealant** - A min 1/8 in. (3 mm) wet thickness (min 1/16 in. or 1.6 mm dry thickness) of fill material applied on each side of wall to completely cover forming material and to overlap min 1/2 in. (13 mm) onto wall and min 2 in. (51 mm) onto spray-applied fire resistive material.

SPECIFIED TECHNOLOGIES INC - SpecSeal AS200 Elastomeric Spray

- C. **Fill, Void or Cavity Material* - Sealant** - (Not Shown) - As an alternate to Items 3A and 3B, min 5/8 in. (16 mm) depth of sealant applied within joint flush with each side of wall.

SPECIFIED TECHNOLOGIES INC - SpecSeal ES Sealant

*Bearing the UL Classification Mark



Specified Technologies Inc. 210 Evans Way Somerville, NJ 08876

Reproduced courtesy of Underwriters Laboratories, Inc.

Created or Revised: November 10, 2011

(800)992-1180 • (908)526-8000 • FAX (908)231-8415 • E-Mail:techserv@stifirestop.com • Website:www.stifirestop.com



HW-D-0617
PAGE 4 OF 4