

System No. HW-D-0619

Assembly Ratings -1 and 2 Hr (See Item 2)
Nominal Joint Width - 3/4 in. or 1 in. (See Item 3)
Class II and III Movement Capabilities - 19 or 100% Compression or
Extension (See Item 3A or 3A1)
L Rating at Ambient-Less than 1 CFM/Lin Ft
L Rating at 400°F-Less than 1 CFM/Lin Ft

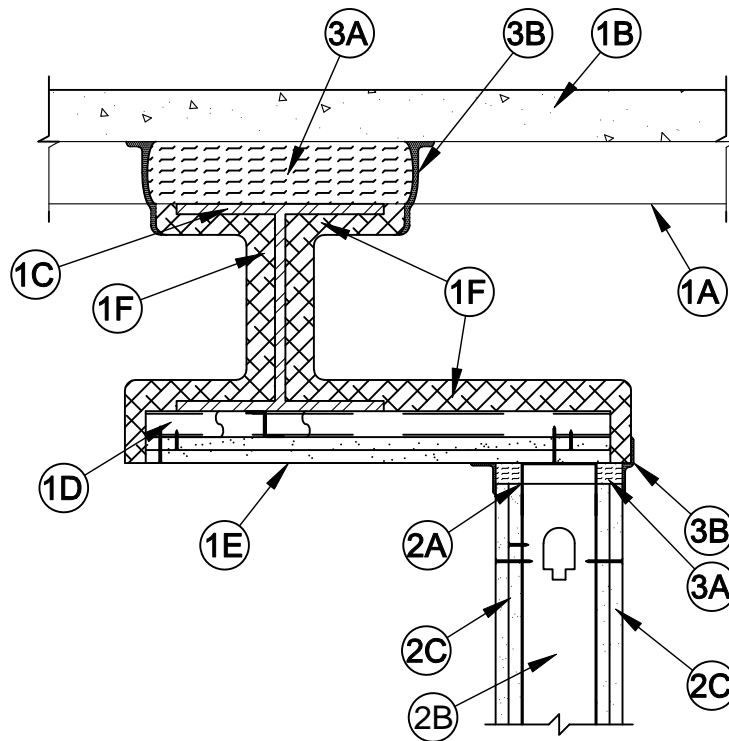

1. **Floor Assembly** - The fire-rated fluted steel deck/concrete floor assembly shall be constructed of the materials and in the manner described in the individual D700 or D900 Series Floor-Ceiling Design in the UL Fire Resistance Directory and shall include the following construction features:
 - A. **Steel Floor And Floor Units*** - Max 3 in. (76 mm) deep galv steel fluted floor units.
 - B. **Concrete** - Min 2-1/2 in. (64 mm) thick reinforced lightweight or normal weight (100-150 pcf or 1600-2400 kg/m3) concrete, as measured from the top plane of the floor units.
 - C. **Structural Steel Support** - Steel beam, as specified in the individual D700 or D900 Series Floor-Ceiling Design, used to support steel floor units. Structural steel support oriented parallel to and 8 in. (203 mm) max from wall assembly.
 - D. **Steel Attachment Clips** - Min 1 in. (25 mm) wide Z-shaped clips or channels formed from min 16 ga galv or painted steel. Clips to be sized to extend through the thickness of the spray-applied fire-resistive material on the bottom flange of the steel beam with 1-1/2 in. (38 mm) long upper and lower legs. Legs of clips fastened to bottom of beam (prior to application of spray-applied fire-resistive materials) with steel fasteners or welds and to ceiling runner of wall with bolts or screws. Clips spaced max 16 in. (406 mm) OC and extend from steel support beam to flush with non-beam face of wall.
 - E. **Gypsum Board*** - Two layers of 5/8 in. (16 mm) thick glass mat faced (moisture resistant) gypsum board applied to bottom of steel attachment clips. The boards are cut to the length of steel attachment clips and secured to each clip. Base layer attached to the clips using 1 in. (25 mm) long Type S bugle-head steel screws spaced 12 in. (305 mm) OC, 1 in. (25 mm) max from ends. Outer layer attached to the clips using 1-5/8 in. (41 mm) long Type S bugle-head steel screws spaced 12 in. (305 mm) OC, 1 in. (25 mm) max from ends. Butted joints are centered over clips and joints in base and outer layers to be offset. Joints and screw heads in outer layer covered with two coats of joint compound.



Specified Technologies Inc. 210 Evans Way Somerville, NJ 08876

Reproduced courtesy of Underwriters Laboratories, Inc.
Created or Revised: April 19, 2011

(800)992-1180 • (908)526-8000 • FAX (908)231-8415 • E-Mail:techserv@stifirestop.com • Website:www.stifirestop.com



HW-D-0619
PAGE 1 OF 4

- F. **Spray-Applied Fire Resistive Material*** - After installation of the steel attachment clips, the structural steel support and steel floor units (as applicable) are to be sprayed with the min thickness of material specified in the individual D700 or D900 Series Design. Each steel attachment clip to be fully covered with spray applied fire resistive material to the minimum thickness of material required on the flanges of the steel beam and the spaces between the clips shall also be fully filled from beam and over the entire thickness of the wall. Additional material shall be applied to the web of steel beam on each side of wall. The min total thickness of material applied to each side of steel beam web shall be 13/16 in. (21 mm) for 1 hr Assembly Rating and 1-1/2 in. (38 mm) for 2 hr Assembly Rating. When Item 3A is not used, the flutes of the steel floor units are to be filled with material across the entire top flange of the steel beam. For D700 floors, the remainder of the steel floor units shall be sprayed as specified in the individual D700 design.

ISOLATEK INTERNATIONAL - Type 300

W R GRACE & CO - CONN - Type MK-6/HY

- 1A. **Roof Assembly** - (Not Shown) - As an alternate to the floor assembly, a fire rated fluted steel deck roof assembly may be used. The roof assembly shall be constructed of the materials and in the manner described in the individual P700 or P900 Series Roof-Ceiling Design in the UL Fire Resistance Directory. The roof assembly shall include the following construction features:
- A. **Steel Roof Deck** - Max 3 in. (76 mm) deep galv steel fluted roof deck.
 - B. **Roof Insulation** - Min 2-1/4 in. (57 mm) thick poured insulating concrete, as measured from the top plane of the roof deck.
 - C. **Structural Steel Support** - Steel beam, as specified in the individual P700 or P900 Series Design, used to support steel floor units. Structural steel support oriented parallel to and 8 in. (203 mm) max from wall assembly.
 - D. **Steel Attachment Clips** - 1 in. (25 mm) wide Z-shaped clips or channels formed from min 16 ga galv or painted steel. Clips to be sized to extend through the thickness of the spray-applied fire resistive material on the bottom flange of the steel beam with 1-1/2 in. (38 mm) long upper and lower legs. Legs of clips fastened to bottom of beam (prior to application of spray-applied fire-resistive materials) with steel fasteners or welds and to ceiling runner of wall with bolts or screws. Clips spaced max 16 in. (406 mm) OC and extend from steel support beam to flush with non-beam face of wall.
 - E. **Gypsum Board*** - Two layers of 5/8 in. (16 mm) thick glass mat faced (moisture resistant) gypsum board applied to bottom of steel attachment clips. The boards are cut to the length of steel attachment clips and secured to each clip. Base layer attached to the clips using 1 in. (25 mm) long Type S bugle-head steel screws spaced 12 in. (305 mm) OC, 1 in. (25 mm) max from ends. Outer layer attached to the clips using 1-5/8 in. (41 mm) long Type S bugle-head steel screws spaced 12 in. (305 mm) OC, 1 in. (25 mm) max from ends. Butted joints are centered over clips and joints in base and outer layers to be offset. Joints and screw heads in outer layer covered with two coats of joint compound. An additional nominal 9 in. (229 mm) wide strip of gypsum board covering the exposed leg of the ceiling runner attached to the ceiling runner and to the 1-1/2 by 1 1/2 in. (38 by 38 mm) galv steel angle (see Item 2A) with min 1 in. (25 mm) long fasteners spaced a max of 12 in. (305 mm) on center and 1 in. (25 mm) max from ends along track and angle on the non-finished side of wall. This strip of gypsum shall extend above the ceiling track to be flush with top of spray applied fire resistive material on steel attachment clips, and the strip shall extend down min 1-1/2 in. (38 mm) below the exposed leg of ceiling track.
 - F. **Spray-Applied Fire Resistive Material*** - After installation of the steel attachment clips, the structural steel support and roof deck (as applicable) are to be sprayed with the min thickness of material specified in the individual P700 or P900 Series Design. Each steel attachment clip to be fully covered with spray applied fire resistive material to the minimum thickness of material required on the flanges of the steel beam and the spaces between the clips shall also be fully filled from beam and over the entire thickness of the wall. Additional material shall be applied to the web of steel beam on each side. The min total thickness of material applied to each side of steel beam web shall be 13/16 in. (21 mm) for 1 hr Assembly Rating and 1-1/2 in. (38 mm) for 2 hr Assembly Rating. When Item 3A is not used, the flutes of the roof deck are to be filled with material across the entire top flange of the steel beam. For P700 roof-ceiling assemblies, the remainder of the roof deck shall be sprayed as specified in the individual P700 design.

ISOLATEK INTERNATIONAL - Type 300

W R GRACE & CO - CONN - Type MK-6/HY

- 1B. **Floor Assembly** - (Not Shown) - As an alternate to the floor assembly (Item 1), min 4-1/2 in. (114 mm) thick reinforced lightweight or normal weight (100 to 150 pcf or 1600-2400 kg/m³) structural concrete slab.



Specified Technologies Inc. 210 Evans Way Somerville, NJ 08876

Reproduced courtesy of Underwriters Laboratories, Inc.
Created or Revised: April 19, 2011

(800)992-1180 • (908)526-8000 • FAX (908)231-8415 • E-Mail:techserv@stifirestop.com • Website:www.stifirestop.com



HW-D-0619
PAGE 2 OF 4

2. **Wall Assembly** - The 1 or 2 hr fire rated gypsum board/stud wall assembly shall be constructed of the materials and in the manner described in the individual U400 or V400 Series Wall and Partition Design in the UL Fire Resistance Directory and shall include the following construction features:
- A. **Steel Floor and Ceiling Runners** - Floor and ceiling runners of wall assembly shall consist of galv steel channels sized to accommodate steel studs (Item 2B). Ceiling runner to be provided with min 2 in. (51 mm) to max 3 in. (76 mm) flanges. Ceiling runner to be secured through gypsum board material to steel attachment clips with min 2 in. (51 mm) long steel fasteners spaced at a max spacing of 16 in. (406 mm) OC (min one fastener into each clip).
 - A1. **Light Gauge Framing*** - Slotted Ceiling Runner - As an alternate to the ceiling runner in Item 2A, ceiling runner to consist of galv steel channel with slotted flanges sized to accommodate steel studs (Item 2B). Ceiling runner to be secured through gypsum board material to steel attachment clips with min 2 in. (51 mm) long steel fasteners spaced at a max spacing of 16 in. (406 mm) OC (min one fastener into each clip).

BRADY CONSTRUCTION INNOVATIONS INC,

DBA SLIPTRACK SYSTEMS - SLP-TRK

CALIFORNIA EXPANDED METAL PRODUCTS CO - CST

- A2. **Light Gauge Framing*** - Clipped Ceiling Runner - As an alternate to the ceiling runner in Items 2A and 2A1, clipped runner to consist of galv steel channel with clips preformed in track flanges which positively engage the inside flange of the steel studs (Item 2B). Track sized to accommodate steel studs (Item 2B). Track flanges to be min 2-1/2 in. (64 mm). Clipped ceiling runner to be secured through gypsum board material to steel attachment clips with min 2 in. (51 mm) long steel fasteners spaced at a max spacing of 16 in. (406 mm) OC (min one fastener into each clip).

TOTAL STEEL SOLUTIONS L L C - Snap Trak

- B. **Studs** - Steel studs to be min 3-1/2 in. (89 mm) wide. Studs cut 1/2 in. to 3/4 in. (13 to 19 mm) less in length than assembly height with bottom nesting in and secured to floor runner. Studs to nest in ceiling runner without attachment unless slotted ceiling runner is used. When slotted ceiling runner (Item 2A1) is used, steel studs secured to slotted ceiling runner with No. 8 by 1/2 (13 mm) long wafer head steel screws at mid-height of slot on each side of wall.
- C. **Gypsum Board*** - Gypsum board sheets installed to a min total 5/8 in. (16 mm) or 1-1/4 in. (32 mm) thickness on each side of wall for 1 and 2 hr fire rated assemblies, respectively. Wall to be constructed as specified in the individual U400 or V400 Series Design in the UL Fire Resistance Directory except that a max 3/4 or 1 in. (19 or 25 mm) gap shall be maintained between the top of the gypsum board and the bottom of the gypsum board on the steel attachment clips. The screws attaching the gypsum board to the studs along the top of the wall shall be located 1 in. (25 mm) below the bottom of the ceiling runner. No gypsum board attachment screws shall be driven into the ceiling runner. Where the top of the wall assembly is inaccessible above the lowest elevation of the structural steel support, the gypsum board may be omitted.

The hourly rating of the joint system is equal to the lesser of the hourly ratings of the floor/roof-ceiling assembly and the wall assembly.

3. **Joint System** - Max separation between the gypsum board on the steel attachment clips and top of wall (at time of installation of joint system) is 3/4 or 1 in. (19 or 25 mm). When Item 3A1 is used in lieu of the mineral wool strips described in Item 3A, the maximum joint width is 3/4 in. (19 mm) and the movement capability of the joint system is 100 percent compression or extension. Otherwise, the movement capability of the joint system is 19 percent compression or extension. The joint system shall consist of forming and fill materials, as follows:
- A. **Forming Material*** - Min 4 pcf (64 kg/m³) mineral wool insulation cut to the shape of the fluted steel floor or roof deck units, approx 33 percent larger than the area of the flutes. Pieces compressed and inserted into and completely filling the flutes above the structural support member. As an option, the spray-applied fire resistive material described in Item 1 can be used in place of the packing material within the area of the flutes. Additional sections of mineral wool batt insulation cut to a width equal to the thickness of the gypsum board layer(s) and compressed 50 percent in thickness. Mineral wool strips installed flush with wall surfaces.
- FIBREX INSULATIONS INC - FBX Safing Insulation**
- IIG MINWOOL L L C - MinWool-1200 Safing**
- ROCK WOOL MANUFACTURING CO - Delta Board**
- ROCKWOOL MALAYSIA SDN.BHD - SAF Mineral Wool**
- ROXUL INC - SAF Mineral Wool**
- THERMAFIBER INC - Type SAF**



Specified Technologies Inc. 210 Evans Way Somerville, NJ 08876

Reproduced courtesy of Underwriters Laboratories, Inc.
Created or Revised: April 19, 2011

(800)992-1180 • (908)526-8000 • FAX (908)231-8415 • E-Mail:techserv@stifirestop.com • Website:www.stifirestop.com



HW-D-0619
PAGE 3 OF 4

A1. **Forming Material*** - (Not Shown) - As an option to Item 3A when the nominal joint width is 3/4 in. (19 mm) or less, nom 3/16 in. (4.8 mm) thick by 4 in. (102 mm) high joint forming material profile installed on both sides of the wall assembly. Profile installed by first marking a line across the top of the wall 3 in. (76 mm) below the bottom plane of the steel floor or roof deck valleys. Joint profile material positioned with its top edge against both the underside of the spray-applied fire-resistive material with its bottom edge on the line scribed on the wall assembly. Bottom of the joint profile attached to gypsum board with nom 1/2 in. (13 mm) long steel staples spaced not greater than 8 in. (203 mm) OC. Adjoining lengths of profile to overlap approx 3/4 in. (19 mm) at rabbeted ends. When Item 3A1 is used, the movement capability of the joint system is 100 percent compression or extension.

SPECIFIED TECHNOLOGIES INC - SpecSeal Speed Flex Joint Profile

B. **Fill, Void or Cavity Material* - Spray** - Min 1/16 in. (1.6 mm) dry thickness (min 1/8 in. or 3.2 mm wet thickness) of fill material spray applied atop forming material (Item 3A or 3A1) with 1/2 in. (13 mm) overlap onto gypsum board and steel deck. When the spray applied fill material laps onto SFRM, the minimum overlap shall be 2 in. (51 mm).

SPECIFIED TECHNOLOGIES INC - SpecSeal AS200 Elastomeric Spray

*Bearing the UL Classification Mark



Specified Technologies Inc. 210 Evans Way Somerville, NJ 08876

Reproduced courtesy of Underwriters Laboratories, Inc.

Created or Revised: April 19, 2011

(800)992-1180 • (908)526-8000 • FAX (908)231-8415 • E-Mail:techserv@stifirestop.com • Website:www.stifirestop.com



HW-D-0619
PAGE 4 OF 4