

System No. W-J-2059

F Rating - 4 Hr

T Rating - 4 Hr

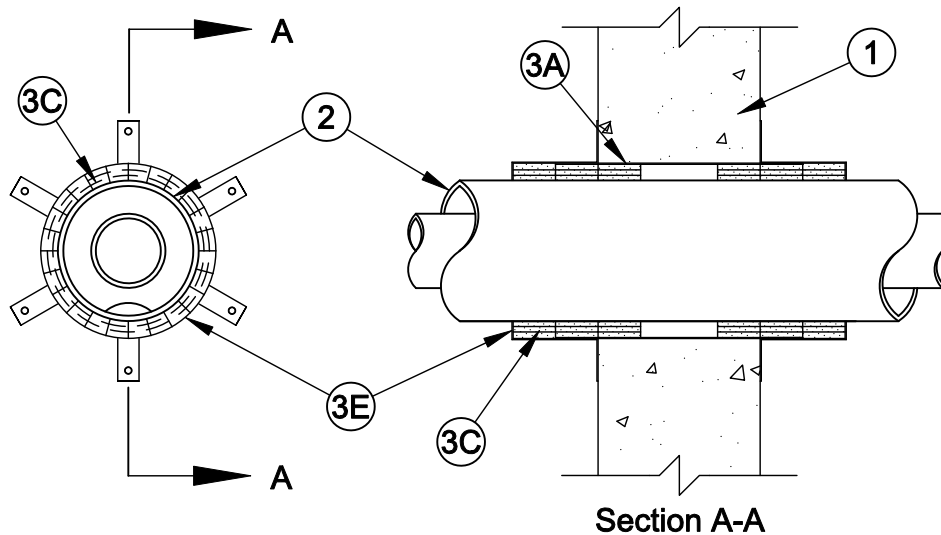

1. **Wall Assembly** - Min 7-5/8 in. (194 mm) thick reinforced lightweight or normal weight (100-150 pcf or 1600-2400 kg/m³) concrete wall assembly. Wall may also be constructed of any UL Classified **Concrete Blocks***. Max diam of opening is 8 in. (203 mm) .

See **Concrete Blocks** (CAZT) category in the Fire Resistance Directory for names of manufacturers.

2. **Through Penetrants** - One nonmetallic pipe concentrically installed within a second nonmetallic pipe and centered within the firestop system. The space between the outer pipe and the periphery of the opening shall be nom 11/16 to 13/16 in. (18 to 21 mm). Nonmetallic spacers shall be used to maintain the inner pipe within the center of the outer pipe at a distance of no closer than 10 in. (254 mm) from both surfaces of wall assembly. Outer pipe to be rigidly supported on both sides of wall assembly. The following types and sizes of nonmetallic pipes described in Items A and B may be used for the outer pipe and the pipes described in Items C and D may be used for the inner pipe:
 - A. **Polypropylene (PP) Pipe** - Nom 6 in. (152 mm) diam (or smaller) SDR32 PP pipe for use in closed (process or supply) or vented (drain, waste or vent) piping systems.
 - B. **Polyvinyl Chloride (PVC) Pipe** - Nom 6 in. (152 mm) diam (or smaller) Schedule 40 PVC pipe for use in closed (process or supply) or vented (drain, waste or vent) piping systems.
 - C. **Polypropylene (PP) Pipe** - Nom 3 in. (76 mm) diam (or smaller) SDR32 pipe for use in closed (process or supply) or vented (drain, waste or vent) piping systems.
 - D. **Polyvinyl Chloride (PVC) Pipe** - Nom 3 in. (76 mm) diam (or smaller) Schedule 40 PVC pipe for use in closed (process or supply) or vented (drain, waste or vent) piping systems.



Specified Technologies Inc. 210 Evans Way Somerville, NJ 08876

Reproduced courtesy of Underwriters Laboratories, Inc.

Created or Revised: January 2, 2009

(800)992-1180 • (908)526-8000 • FAX (908)231-8415 • E-Mail:techserv@stifirestop.com • Website:www.stifirestop.com



W-J-2059
PAGE 1 OF 2

3. **Firestop System** - The firestop system shall consist of the following:

- A. **Metallic Sleeve** - Cylindrical sleeve fabricated from 0.031 in. (0.8 mm) thick (No. 22 MSG) galv sheet steel and having a 2 in. (51 mm) lap along the longitudinal seam. Length of steel sleeve to be 4 in. (102 mm) greater than the thickness of the wall. Sleeve installed by coiling the sheet steel to a diam less than the through opening, inserting the coil through the opening and releasing the coil to let it uncoil against the through opening. The ends of the sleeve shall extend 2 in. (51 mm) beyond each surface of the wall. The metallic sleeve shall be coiled tightly around wrap strip layers (Item 3C) and temporarily secured with aluminum foil tape (Item 3B) until installation and attachment of the steel collars (Item 3D).
- B. **Aluminum Foil Tape** - (Not shown)-Nom 3 mil (0.08 mm) thick pressure sensitive aluminum foil tape wrapped around the circumference of the outer pipe with a min 1 in. (25 mm) wide overlap along its perimeter joint. Foil tape shall begin at the outer edge of the metallic sleeve (Item 3A) and extend 3 in. (76 mm) beyond the sleeve edge on both sides of the wall.
- C. **Fill, Void or Cavity Materials*-Wrap Strip** - Nom 1/8 or 3/16 in. (3.2 or 4.8 mm) thick intumescent material faced on both sides with a plastic film, supplied in 2 in. (51 mm) wide strips. Three stacks of three layers are individually wrapped around the outer pipe with the ends butted and held in place with tape. Butted ends in successive layers may be aligned or offset. The first stack of wrap strips shall be slid along the through penetrant into sleeve such that edges of wrap strips are recessed 2 in. (51 mm) from edges of the sleeve. The second stack of wrap strips shall be slid along the through penetrant into the sleeve such that the edges of the strip wrap about the first stack. The third stack shall be installed such that the edges of the wrap strips about the second stack. Three stacks of wrap strips are required on each side of the wall.

SPECIFIED TECHNOLOGIES INC - SpecSeal BLU Wrap Strip or SpecSeal BLU2 Wrap Strip

- D. **Fill, Void or Cavity materials*-Sealant** - (Not shown)-Min 1/2 in. (13 mm) thickness of fill material applied within the annulus between the metallic sleeve and the periphery of the opening on both sides of the wall.

SPECIFIED TECHNOLOGIES INC - SpecSeal Series SSS Sealant or SpecSeal LCI Sealant

- E. **Steel Collar** - Collar fabricated from coils of precut 0.029 in. (0.7 mm) thick (No. 22 MSG) galv sheet steel available from wrap strip manufacturer. Collar shall be nom 4 in. deep with a min of six 1 in. (25 mm) wide by 2 in. (51 mm) long anchor tabs. Retainer tabs, 3/4 in. (19 mm) wide tapering down to 3/8 in. (10 mm) wide and located opposite the anchor tabs, are bent inward 90 deg to retain the wrap strips. Steel collar wrapped around wrap strips and ends of metallic sleeve with a min 1 in. (25 mm) wide overlap along its perimeter joint. Steel collar tightened and secured to metallic sleeve with four No. 8 by 3/8 in. (10 mm) long sheet metal screws symmetrically located around the perimeter of the steel collar. Steel collars installed on both sides of the wall assembly.

*Bearing the UL Classification Mark



Specified Technologies Inc. 210 Evans Way Somerville, NJ 08876

Reproduced courtesy of Underwriters Laboratories, Inc.
Created or Revised: January 2, 2009

(800)992-1180 • (908)526-8000 • FAX (908)231-8415 • E-Mail:techserv@stifirestop.com • Website:www.stifirestop.com



W-J-2059
PAGE 2 OF 2