

System No. W-J-3142

F Ratings - 3 and 4 hr (See Item 1)
T Rating - 0 Hr

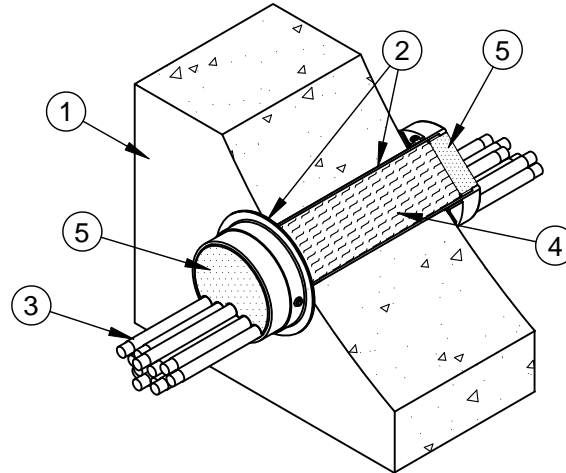

1. **Wall Assembly** - Min 7-5/8 in. (194 mm) thick reinforced lightweight or normal weight (100-150 pcf or 1600-2400 kg/m³) concrete. Wall assembly may also be constructed of any nom 8 in. (203 mm) UL Classified **Concrete Blocks*** with Classification C-3 (3 hr) or B-4 (4 hr). Max diam of opening is 4-1/2 in. (114 mm).

See **Concrete Blocks** (CAZT) category in the Fire Resistance Directory for names of manufacturers.

The hourly F rating of the firestop system is equal to the hourly fire rating of the wall assembly in which it is installed.

2. **Firestop Device*** - Steel sleeve device centered within opening and installed in accordance with the accompanying installation instructions. Steel sleeve device secured in place by means of steel escutcheon plates installed with gasketing material supplied with product. Steel escutcheon plates installed on both sides of wall and secured to device by means of steel screws provided with device. Steel sleeve device provided in nom 1, 2 and 4 in. (25, 51 and 102 mm) sizes. The min and max opening sizes for each sleeve device are shown in the table below:

Device Size	Min Opening Size	Max Opening Size
1 in. (25 mm)	1.12 in. (28 mm)	1.25 in. (32 mm)
2 in. (51mm)	2.38 in. (60 mm)	2.50 in. (64 mm)
4 in. (102 mm)	4.50 in. (114 mm)	4.50 in. (114 mm)

SPECIFIED TECHNOLOGIES INC - FS100, FS200 and FS400 SpecSeal Ready-Sleeves

3. **Cables** - Aggregate cross-sectional area of cables in steel sleeve to be max 34 percent of the aggregate cross-sectional area of the sleeve. Cables to be rigidly supported on both sides of wall assembly. Any combination of the following types and sizes of copper conductor cable may be used:
 - A. Max RG/U (or smaller) coaxial cable with fluorinated ethylene insulation and jacketing.
 - B. Max 62.5/48 fiber optic cable with PVC insulation and jacketing.
 - C. Max 4 pair No. 24 AWG (or smaller) copper conductor data cable with PVC insulation and jacket.
4. **Packing Material** - Mineral wool batt insulation, nom 4 pcf (64 kg/m³), packed tightly into sleeve to full depth except for a recess at each end as required to accommodate the required thickness of fill material (Item 5).
5. **Fill, Void or Cavity Material* - Putty** - Fill material supplied with firestop device (Item 2) applied to 1 in. (25 mm) thickness flush with each end of steel sleeve device (Item 2). At point contact location, apply min 3/8 in. (9 mm) diam bead of fill material at grouped cable/steel sleeve interface on each side of wall.

SPECIFIED TECHNOLOGIES INC - SpecSeal Putty

*Bearing the UL Classification Mark



Specified Technologies Inc. 210 Evans Way Somerville, NJ 08876

Reproduced courtesy of Underwriters Laboratories, Inc.
Created or Revised: June 16, 2007

(800)992-1180 • (908)526-8000 • FAX (908)231-8415 • E-Mail:techserv@stifirestop.com • Website:www.stifirestop.com



W-J-3142
PAGE 1 OF 1