

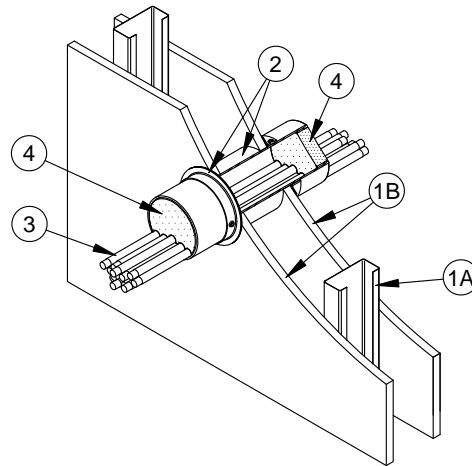

System No. W-L-3275

F Ratings - 1 and 2 hr (See Item 1)
T Rating - 0 Hr



1. **Wall Assembly** - The 1 or 2 hr fire rated gypsum board/stud wall assembly shall be constructed of the materials and in the manner specified in the individual U300, U400 or V400 Series Wall and Partition Designs in the UL Fire Resistance Directory and shall include the following construction features:
 - A. **Studs** - Wall framing may consist of either wood studs or steel channel studs. Wood studs to consist of nom 2 by 4 in. (51 by 102 mm) lumber spaced 16 in. (406 mm) OC. Steel studs to be min 3-1/2 in. (89 mm) wide and spaced max 24 in. (610 mm) OC
 - B. **Gypsum Board*** - 5/8 in. (16 mm) thick, 4 ft (1.2 m) wide with square or tapered edges. The gypsum board type, thickness, number of layers, fastener type and sheet orientation shall be as specified in the individual U300, U400 or V400 Series Design in the UL Fire Resistance Directory. Max diam of opening is 4-1/2 in. (114 mm).

The hourly F rating of the firestop system is equal to the hourly fire rating of the wall assembly in which it is installed.
2. **Firestop Device*** - Steel sleeve device centered within opening and installed in accordance with the accompanying installation instructions. Steel sleeve device secured in place by means of steel escutcheon plates installed with gasketing material supplied with product. Steel escutcheon plates installed on both sides of wall and secured to device by means of steel screws provided with device. Steel sleeve device provided in nom 1, 2 and 4 in. (25, 51 and 102 mm) sizes. The min and max opening sizes for each sleeve device are shown in the table below:

Device Size	Min Opening Size	Max Opening Size
1 in. (25 mm)	1.12 in. (28 mm)	1.25 in. (32 mm)
2 in. (51 mm)	2.38 in. (60 mm)	2.50 in. (64 mm)
4 in. (102 mm)	4.50 in. (114 mm)	4.50 in. (114 mm)

SPECIFIED TECHNOLOGIES INC - FS100, FS200 and FS400 SpecSeal Ready-Sleeves



Specified Technologies Inc. 210 Evans Way Somerville, NJ 08876

Reproduced courtesy of Underwriters Laboratories, Inc.
Created or Revised: May 16, 2006

(800)992-1180 • (908)526-8000 • FAX (908)231-8415 • E-Mail:techserv@stifirestop.com • Website:www.stifirestop.com



W-L-3275
PAGE 1 OF 2

3. **Cables** - Aggregate cross-sectional area of cables in steel sleeve to be max 48 percent of the aggregate cross-sectional area of the sleeve. Cables to be rigidly supported on both sides of wall assembly. Any combination of the following types and sizes of copper conductor cable may be used:
- A. Max 200 pair No. AWG (or smaller) copper conductor cable with polyvinyl chloride (PVC) jacketing and insulation.
 - B. Max 3/C No. 2/0 AWG (or smaller) aluminum or copper conductor service entrance cable with PVC insulation and jacket.
 - C. Max 3/C No. 8 AWG (or smaller) nonmetallic sheathed (Romex) cable with copper conductors, PVC insulation and jacket.
 - D. Max 7/C No. 2/0 AWG (or smaller) multiconductor power and control cables with XLPE or PVC insulation and XLPE or PVC jacket.
 - E. Max RG/U (or smaller) coaxial cable with fluorinated ethylene insulation and jacketing.
 - F. Max 62.5/48 fiber optic cable with PVC insulation and jacketing.
 - G. Max 4 pair No. 24 AWG (or smaller) copper conductor data cable with PVC insulation and jacket.
 - H. Max 4/C No. 2/0 aluminum or copper conductor aluminum or steel Metal-Clad# or Armored-Clad# cable.
4. **Fill, Void or Cavity Material* - Putty** - Fill material supplied with firestop device (Item 2) applied to 1 in. (25 mm) thickness flush with each end of steel sleeve device (Item 2). At point contact location, apply min 3/8 in. (9 mm) diam bead of fill material at grouped cable/steel sleeve interface on each side of wall.

SPECIFIED TECHNOLOGIES INC - SpecSeal Putty

*Bearing the UL Classification Mark



Specified Technologies Inc. 210 Evans Way Somerville, NJ 08876

Reproduced courtesy of Underwriters Laboratories, Inc.
Created or Revised: May 16, 2006

(800)992-1180 • (908)526-8000 • FAX (908)231-8415 • E-Mail:techserv@stifirestop.com • Website:www.stifirestop.com



W-L-3275
PAGE 2 OF 2