

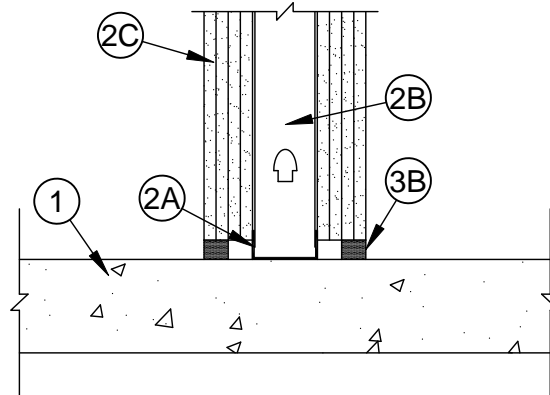

### System No. BW-S-0017

Assembly Ratings - 3 and 4 Hr (See Item 2)  
Joint Width - 3/4 In. (19 mm) Max



1. **Floor Assembly** - Min 4-1/2 in. (115 mm) thick reinforced lightweight or normal weight (100-150 pcf or 1600-2400 kg/m<sup>3</sup>) structural concrete. Floor may also be constructed of any 6 in. (152 mm) thick UL Classified hollow-core Precast Concrete Units\*.

See **Precast Concrete Units** category in the Fire Resistance Directory for names of manufactures.

2. **Wall Assembly** - The 3 or 4 h fire-rated gypsum board/steel stud wall assembly shall be constructed of the materials and in the manner specified in the individual U400 or V400 Series Wall or Partition Design in the UL Fire Resistance Directory. In addition, the wall may incorporate a head-of-wall joint system constructed as specified in the HW Series Joint Systems in the UL Fire Resistance Directory. The wall shall include the following construction features:

- A. **Steel Floor Runner** - Floor runners of wall assembly shall consist of min No. 25 gauge (0.56 mm) galv steel channels sized to accommodate steel studs (Item 2B). Floor runners to be provided with min 1-1/4 in. (31 mm) flanges. Runners secured with steel fasteners spaced 12 in. (305 mm) OC.
- B. **Studs** - Steel studs to be min 3-1/2 in. (89 mm) wide. Studs cut 1/2 to 3/4 in. (13 to 19 mm) less in length than assembly height with bottom nesting in, resting on and fastened to floor runner with sheet metal screws. Stud spacing not to exceed 24 in. (610 mm) OC.
- C. **Gypsum Board\*** - Multiple layers of min 1/2 in. (13 mm) thick gypsum board. Wall to be constructed as specified in the individual U400 or V400 Series Design in Wall and Partition Design in the UL Fire Resistance Directory, except that a max 3/4 in. (19 mm) gap shall be maintained between the bottom of the gypsum board and the top of the concrete floor.

The hourly fire rating of the joint system is equal to the hourly fire rating of the wall.

3. **Joint System - Max separation between top of floor and bottom of gypsum board is 3/4 in. (19 mm).** The joint system consists of a packing material and a fill material, as follows:

- A. **Packing Material** - (Optional, Not Shown) - Mineral wool batt insulation, polyethylene backer rod or glass fiber insulation firmly packed into the gap between the bottom of the gypsum board and the top of the concrete floor and recessed from each surface of the wall to accommodate the required thickness of fill material.
- B. **Fill, Void or Cavity Material\*-Sealant** - Min 1 in. (13 mm) thickness of fill material installed on each side of the wall between the bottom of the gypsum board and the top of the concrete floor, flush with each surface of the wall.

**SPECIFIED TECHNOLOGIES INC** - SpecSeal ES Sealant, Pensil 300 Sealant or SpecSeal Series SIL300

\*Bearing the UL Classification Mark

**FOR CANADIAN APPLICATIONS:**  
When evaluated in accordance with ULC-S115, this system has the following ratings:

System No.	Rating Hr.			
	F	FT	FH	FTH
BW-S-0017	3 & 4	3 & 4	3 & 4	3 & 4

For more information, please see the XHHW7.R14288 section in the UL Fire Resistance Directory entitled Fill, Void or Cavity Materials Certified for Canada.



**Specified Technologies Inc. 210 Evans Way Somerville, NJ 08876**

Reproduced courtesy of Underwriters Laboratories, Inc.

Created or Revised: October 09, 2009

(800)992-1180 • (908)526-8000 • FAX (908)231-8415 • E-Mail:techserv@stifirestop.com • Website:www.stifirestop.com



BW-S-0017  
PAGE 1 OF 1