



SERIES ES ELASTOMERIC SEALANT

APPLICATIONS

SpecSeal® Elastomeric Sealant is designed primarily for the protection of construction joints.

PHYSICAL PROPERTIES

Table A:

PRODUCT NAME	Series ES
Color	Pale Blue or Red
Odor	Mild Latex
Density	10 Lb/Gal (1.19 kg/L)
Solids	66%
pH	7.5
In-Service Temp.	≤120°F (49°C)
Storage Temp.	40°F (4°C) - 95°F (35°C)
Flame Spread	5*
Smoke Development	5*
Movement	±25%**
Solvent Content	None
Drying Time	Tack Free 2 Hours ^A Dry through 5 to 7 days ^A
STC Rating	62
Shelf Life	2 yrs
VOC	15 g/L (.125 lb/gal.)
* Tested to ASTM E84 (UL723) at 14% surface	
**500 Cycles per UL2079, AC30 (ICBO) and ASTM E1399	
^A Dependent on temperature and humidity	

PRODUCT DESCRIPTION

SpecSeal® Elastomeric Sealant is a non-halogenated latex-based, highly elastomeric caulk designed to provide passive smoke and fire protection in construction joints. This material is also designed to restore sound attenuation properties to sound-rated ceilings and partitions.

SpecSeal® Elastomeric Sealant is engineered to adhere to virtually all construction surfaces and may be applied using standard caulking equipment or by troweling. SpecSeal® Elastomeric Sealant dries to form a flexible shield against the propagation of fire. Its premium latex binder system is totally resistant to water and will not re-emulsify after drying. SpecSeal® Elastomeric Sealant contains no inorganic fibers, asbestos, or solvents.

FEATURES

- **Water-Based** for easy installation and cleanup.
- **Non-halogenated.**
- **Thixotropic** for high-build application.
- **Auto bonding.**
- **Safe...** No solvents! No asbestos!
- **Elastomeric!**
- **Water-Resistant!**
- **UL Classified.**
- **Acoustical** sealant
- **Paintable**

PERFORMANCE

When applied to a wet film thickness of 1/4" (6.3 mm) to 1/2" (12.5 mm) over appropriate backing materials, SpecSeal® Elastomeric Sealant has been successfully tested in one, two, three and four hour joints when tested in accordance with UL2079 (ASTM E1966). All tested systems have been cycled 500 times at total movement up to ± 25%. Consult factory for individual system designs and application requirements.

LIMITATIONS: Use product as per manufacturer's instructions. Use only in applications per the manufacturer's tested and published designs or per specific recommendations. End user must ultimately determine the suitability of the product and designs to his specific requirement and assumes responsibility for its use.

FIG. 1: EXAMPLE OF MAINTAINING STC VALUES OF WALL AND CREATING AN EFFECTIVE SOUND BARRIER

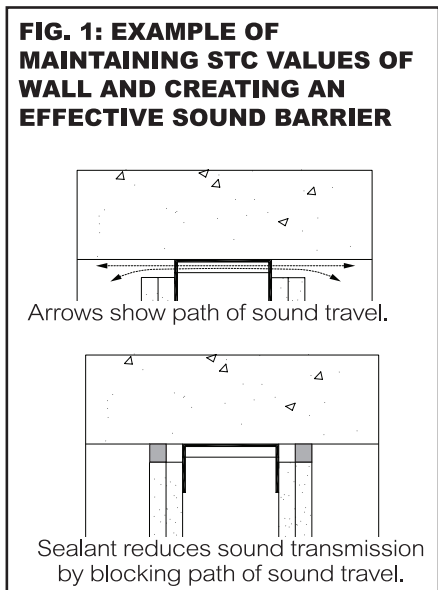

CLASSIFIED
C **UL** US

FILL, VOID OR CAVITY MATERIALS CLASSIFIED BY UNDERWRITERS LABORATORIES INC. ® FOR USE IN THROUGH-PENETRATION FIRESTOP SYSTEMS.

SEE UL FIRE RESISTANCE DIRECTORY

UNDERWRITERS LABORATORIES INC.® CLASSIFIED WALL PROTECTION MATERIAL. SEE PRODUCT CATEGORY IN UL FIRE RESISTANCE DIRECTORY

CLASSIFIED FILL, VOID, OR CAVITY MATERIALS FOR USE IN THROUGH-PENETRATION FIRESTOP SYSTEMS. SEE UL DIRECTORY OF PRODUCTS CERTIFIED FOR CANADA AND UL FIRE RESISTANCE DIRECTORY

FM
APPROVED

FIG 2: RECOMMENDED JOINT DESIGNS - AVOIDING THREE-POINT ADHESION

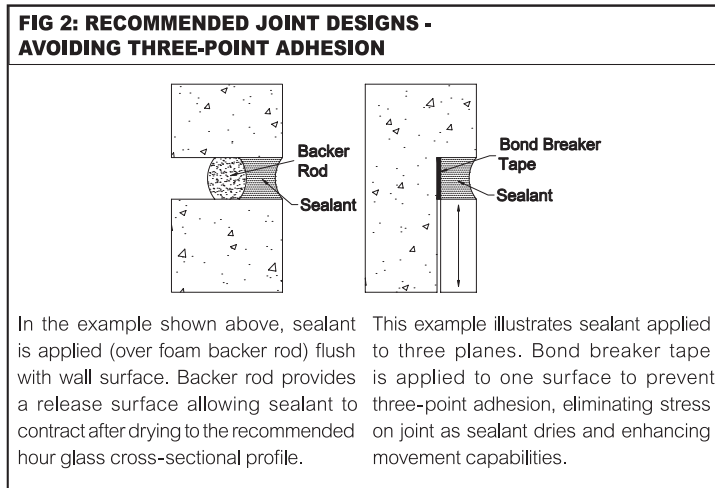

SPECIFICATIONS

The fire protective sealant shall be a water-based, non-halogenated, elastomeric and shall contain no solvents, inorganic fibers, nor asbestos. The sealant shall dry to form a flexible, moisture resistant seal and shall adhere to all common construction surfaces. The sealant shall have demonstrated sound attenuation properties. The approved sealant shall be SpecSeal® Elastomeric Sealant.

SPECIFIED DIVISIONS

DIV. 7 — 07 84 00 Firestopping

DIV. 7 — 07 84 43 Fire Resistant Joint Sealants

INSTRUCTIONS

GENERAL: Areas to be protected must be clean and free of oil, loose dirt, rust or scale. Recommended storage and application temperatures range between 40°F (4°C) and 95°F (35°C). When applying product at the lower end of the temperature range, warming the material to 70°F (21°C) will enhance drying characteristics. Drying time will vary according to prevailing temperature and humidity. Allow to thoroughly dry before exposure to moisture.

Consult appropriate manufacturer's drawing for system design requirements. Forming or packing materials may be required as an integral part of various system designs. See Table B for estimation information.

Sealant is auto-bonding and may be applied in stages. **DO NOT ATTEMPT TO THIN PRODUCT BY ADDING WATER.**

THIS PRODUCT IS DESIGNED FOR PROFESSIONAL INSTALLATION ONLY. This sealant is designed to contract while drying. Proper joint design is critical to sealant performance. Avoid three point adhesion through the use of appropriate backing or bond-breaking materials.

See Figure 2 for recommended joint designs. Consult ASTM C1193 Standard Guide for Use of Joint Sealants for additional guidelines concerning the proper application of sealant materials.

MAINTENANCE

Inspection: Installations should be inspected periodically for subsequent damage. Following safety precautions listed in Precautionary Information and pertinent installation guidelines, remove coating in damaged areas down to undamaged material. Reapply fresh coating material to original coating thickness.

FIG. 3: HEAD-OF-WALL JOINT - GYPSUM WALLBOARD WALL TO CONCRETE FLOOR

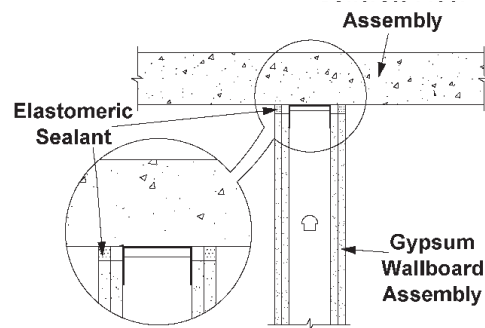

UL System No. HW-D-0079

Assembly Rating – 1 & 2 Hr • Movement Capabilities: 25% Compress.
Nominal Joint Width: 3/4" • Forming Material: In 1 hr walls, apply bond breaker tape to ceiling track.
Sealant Depth: 5/8" depth on both sides.

FIG. 4: HEAD-OF-WALL JOINT - GYPSUM WALLBOARD WALL CUT TO FIT CONTOURS OF STEEL DECK

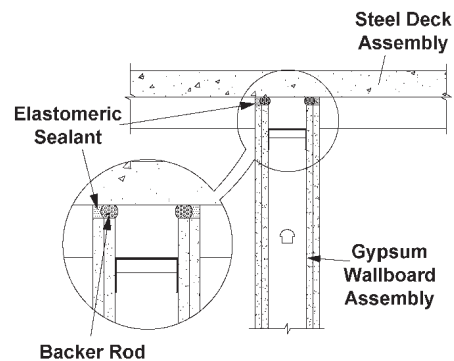

UL System No. HW-D-0103

Assembly Rating – 1 & 2 Hr • Movement Capabilities: 25% Compress.
Nominal Joint Width: 3/4" • Forming Material: In 1 hr walls, apply bond breaker tape to ceiling track.
Sealant Depth: 1/2" depth on both sides.

FIG. 5: HEAD-OF-WALL JOINT - GYPSUM WALLBOARD WALL TO CONCRETE OVER STEEL DECK

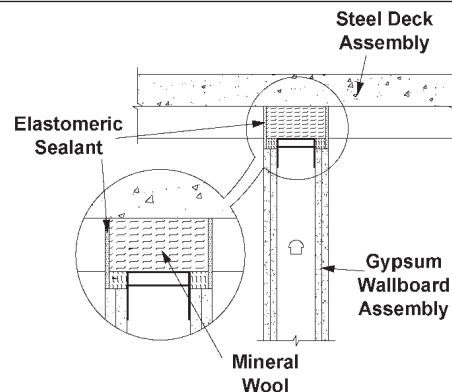

UL System No. HW-D-0034

Assembly Rating – 1 & 2 Hr • Movement Capabilities: ±25% Compress/Extend.
Nominal Joint Width: 1" • Forming Material: Nom 4 pcf mineral wool to full depth.
Sealant Depth: 1/2" depth on both sides.

FIG. 6: HEAD-OF-WALL JOINT - MASONRY WALL TO CONCRETE OVER STEEL DECK

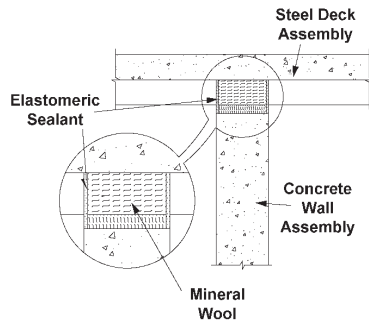

UL System No. HW-D-0039
 Assembly Rating – 2 Hr
 Movement Capabilities: $\pm 25\%$ Compress/Extend.
 Nominal Joint Width: 1"
 Forming Material: Nom 4 pcf mineral wool to full depth.
 Sealant Depth: 1/4" depth on both sides.

FIG. 7: HEAD-OF-WALL JOINT - MASONRY WALL TO CONCRETE FLOOR

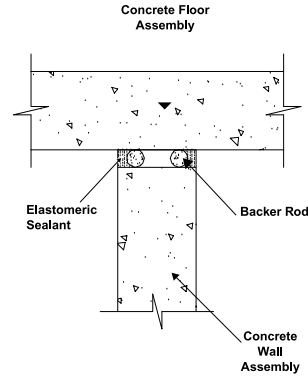

UL System No. HW-D-0041
 Assembly Rating – 3 Hr
 Movement Capabilities: $\pm 12.5\%$ Compress/Extend or 25% Compress.
 Nominal Joint Width: 1" or 3/4" (See System).
 Forming Material: Optional foam backer rod.
 Sealant Depth: 1" or 1/2" (See System) on both sides.

FIG. 8: FLOOR-TO-FLOOR JOINT - CONCRETE FLOOR TO CONCRETE FLOOR

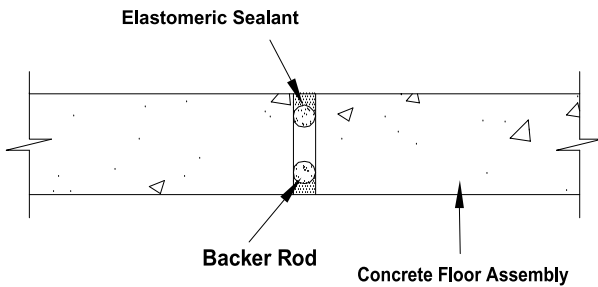

UL System No. FF-D-0005
 Assembly Rating – 3 Hr
 Movement Capabilities: $\pm 12.5\%$ Compress/Extend
 Nominal Joint Width: 1"
 Forming Material: Optional foam backer rod.
 Sealant Depth: 1/2" top and bottom.

FIG. 9: FLOOR-TO-WALL JOINT - CONCRETE FLOOR TO CONCRETE WALL

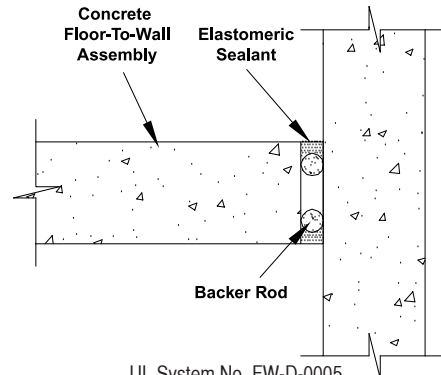

UL System No. FW-D-0005
 Assembly Rating – 3 Hr
 Movement Capabilities: $\pm 12.5\%$ Compress/Extend
 Nominal Joint Width: 1"
 Forming Material: Optional foam backer rod.
 Sealant Depth: 1/2" top and bottom.

FIG. 10: FLOOR-TO-FLOOR JOINT - CONCRETE FLOOR TO CONCRETE FLOOR

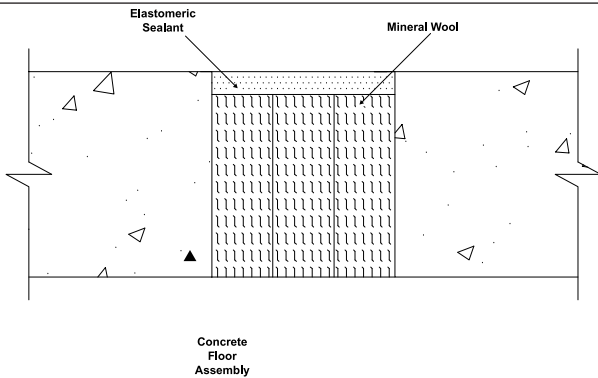

UL System No. FF-D-1008
 Assembly Rating – 3 Hr
 Movement Capabilities: $\pm 15\%$ Compress/Extend
 Nominal Joint Width: 4"
 Forming Material: Nom 4 pcf mineral wool to 4" depth.
 Sealant Depth: 1/2" depth of sealant.

FIG. 11: FLOOR-TO-WALL JOINT - CONCRETE FLOOR TO CONCRETE WALL

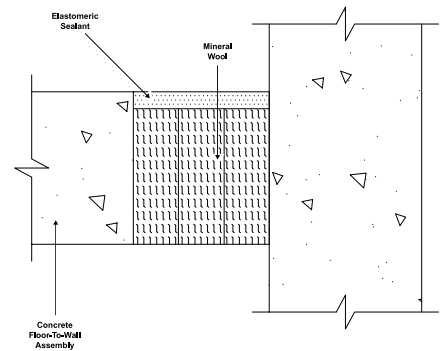

UL System No. FW-D-1007
 Assembly Rating – 3 Hr
 Movement Capabilities: $\pm 15\%$ Compress/Extend
 Nominal Joint Width: 4"
 Forming Material: Nom 4 pcf mineral wool to 4" depth.
 Sealant Depth: 1/2" depth of sealant.



Table B: PRODUCT ESTIMATION INFORMATION (Construction Joints)									
JOINT	PER 1/4" INSTALLED DEPTH			PER 1/2" INSTALLED DEPTH			PER 1" INSTALLED DEPTH		
	WIDTH	CU IN/FT	FT/GAL	GAL/100 FT	CU IN/FT	FT/GAL	GAL/100 FT	CU IN/FT	FT/GAL
0.5	1.5	154	.65	3	77.0	1.3	6	38.5	2.6
0.75	2.3	102	.95	4.5	51.3	1.9	9	25.7	3.9
1.0	3.0	77	1.3	6.0	38.5	2.6	12	19.3	5.2
1.5	4.5	51	2	9.0	25.7	3.9	18	12.8	7.8
2.0	6.0	38	2.6	12	19.3	5.2	24	9.6	10.4
2.5	8.0	31	3.3	15	15.4	6.5	30	7.7	13.0
3.0	9.0	25	3.9	18	12.8	7.8	36	6.4	15.6
3.5	11	22	4.6	21	11.0	9.1	42	5.5	18.2
4.0	12	19	5.2	24	9.6	10.4	48	4.8	20.8
5.0	15	15	6.5	30	7.7	13.0	60	3.9	26.0
6.0	18	12	7.8	36	6.4	15.6	72	3.2	31.2

TECHNICAL SERVICE

Specified Technologies Inc. provides toll free technical support to assist in product selection and appropriate installation design. UL Systems, Material Safety Data Sheets and other technical information is available at the Technical Library at www.stifirestop.com.

PRECAUTIONARY INFORMATION

Consult Material Safety Data Sheet for additional information on the safe handling and disposal of this material. Wash areas of skin contact with soap and water. Avoid contact with eyes. Apply in areas with adequate ventilation.

AVAILABILITY

SpecSeal® Elastomeric Sealant is available from authorized distributors nationwide. Consult factory for the names and locations of the nearest sales representatives or distributors.

ORDERING INFORMATION

SpecSeal® Elastomeric Sealant is available in caulk tubes, sausages and pails.

Cat. No.	Description
ES100	10.1 oz. Tube (300 ml) 18.2 cu.in.
ES129	29.0 oz. Tube (858 ml) 52 cu.in.
ES120	20 oz. Sausage (592 ml) 36 cu. in.
ES105	5 Gal. Pail (19.0 liters) 1,155 cu.in.

CITY OF NEW YORK MEA 290-98-M

IMPORTANT NOTICE: All statements, technical information, and recommendations contained herein are based upon testing believed to be reliable, but the accuracy and completeness thereof is not guaranteed.

WARRANTY

Specified Technologies Inc. manufactures its goods in a manner to be free of defects. Should any defect occur in its goods (within one year), Specified Technologies Inc., upon prompt notification, will at its option, exchange or repair the goods or refund the purchase price.

LIMITATIONS AND EXCLUSIONS:

THIS WARRANTY IS IN LIEU OF ALL OTHER REPRESENTATIONS EXPRESSED OR IMPLIED (INCLUDING THE IMPLIED WARRANTIES OF MERCHANTABILITY OR FITNESS FOR USE) AND UNDER NO CIRCUMSTANCES SHALL SPECIFIED TECHNOLOGIES INC. BE RESPONSIBLE FOR ANY INCIDENTAL OR CONSEQUENTIAL PROPERTY DAMAGE OR LOSSES. PRIOR TO USE, THE USER SHALL DETERMINE THE SUITABILITY OF THE PRODUCT FOR ITS INTENDED USE, AND THE USER ASSUMES ALL RISKS AND LIABILITY FOR SUBSEQUENT USE.

No statement or recommendation not contained herein shall have any force or effect unless in an agreement signed by officers of seller and manufacturer.

MADE IN THE USA – COPYRIGHT © 2008 SPECIFIED TECHNOLOGIES, INC.



Specified Technologies Inc.

Specified Technologies Inc. • 200 Evans Way, Somerville NJ 08876 • Phone: 800.992.1180 • Fax: 908.526.9623

