

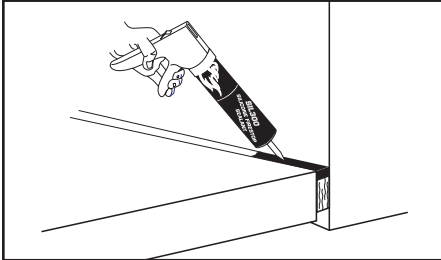

SERIES SIL SILICONE FIRESTOP SEALANT

APPLICATIONS

SpecSeal® Series SIL Silicone Firestop Sealant is used to seal both through-penetration firestop systems and joint systems. Representative systems have been tested involving primarily non-combustible penetrants, electrical, data, or telephone cables, construction gaps, expansion joints, curtain wall safing applications, and top-of-wall joints.



FEATURES

- **Low Modulus** allows dynamic movement in joints.
- **Auto Bonding** allows fresh sealant to adhere to cured sealant.
- **Excellent Water Resistance** for water-tight sealing; including Class 1 W Ratings (UL1479).
- **Ozone and UV Resistant** for excellent weathering ability and long service life.
- **Excellent Chemical Resistance** protects in polluted or corrosive atmospheres.
- **Excellent Adhesion** to most building substrates.
- **Excellent Smoke Seal**
- **Neutral Cure**

SPECIFICATIONS

The silicone firestop sealant shall be a one-part, neutral-cure meeting the requirements of ASTM C920. The firestop sealant shall be UL Classified and tested to ASTM E814 (UL1479), ASTM E1966 (UL2079), and CAN/ULC-S115. Class 1 W Ratings per UL1479 shall be available for a variety of different firestop systems.

SPECIFIED DIVISIONS

DIV.	7	07 84 00	Firestopping
DIV.	7	07 92 00	Joint Sealants
DIV.	22	22 00 00	Plumbing
DIV.	23	23 00 00	HVAC
DIV.	26	26 00 00	Electrical

PRODUCT DESCRIPTION

SpecSeal® Series SIL Silicone Firestop Sealant is a one-part, neutral-curing silicone sealant exhibiting superior performance in applications where sealing openings in walls and floors are needed to control the spread of fire, smoke, toxic gasses, and water during fire conditions.

SpecSeal® Series SIL Silicone Firestop Sealant reacts with atmospheric moisture to form a high-strength, durable seal that will adhere to most building substrates without the use of primers. SpecSeal® products do not contain asbestos or PCBs.

BASIC USES:

SpecSeal® Series SIL Silicone Firestop Sealant is designed for use in firestop systems for through penetrations and joints. This product excels in applications where greater water resistance is required. Systems have been tested for Class 1 W Ratings per UL1479.

SpecSeal® Series SIL Silicone Firestop Sealant is available in non-sag (SIL300) and self-leveling (SIL300SL) grades and may also be used to seal vertical and horizontal joints between metals, masonry, concrete and other common construction materials. SpecSeal® Series SIL Silicone Firestop Sealant is specially designed for use in static or dynamic joints. The low modulus characteristic minimizes strain on the substrate surface and the elastomeric quality allows excellent recovery from extension and compression cycling.

PERFORMANCE

SpecSeal® Series SIL Silicone Firestop Sealants are the basis for systems that meet the exacting criteria of ASTM E814, (UL 1479), ASTM E1966 (UL 2079), ASTM E1399, as well as the time-temperature requirements of ASTM E119 (UL 263). Firestop systems for both joint systems and through penetration firestops have been tested with ratings up to 4 hours. See UL Systems for more specific information.

Additionally, SpecSeal® Series SIL Silicone Firestop Sealant meets ASTM C920, "Standard Specification for Elastomeric Joint Sealants". For SIL300, the product is listed as Type S, Grade NS, Class 50, Use A, G, M, O. For SIL300SL, the product is listed as Type S, Grade P, Class 25, Use A, G, M, O.

Finally, SIL300 (non-sag) has been evaluated by NSF Laboratories for inclusion in Lubrizol's FGG/BM/CZ CPVC System Compatible program.

PHYSICAL PROPERTIES

Typical Properties – As Supplied		
Property	SIL300 (Non-Sag)	SIL300SL (Self-Leveling)
Consistency	Trowelable	Pourable
Percent Solids	100%	85%
VOC, ASTM D2369	20 g/L	130 g/L
Tooling Time	25-30 minutes	25-30 minutes
Tack Free, ASTM C679 (77°F, 50%RH)	3-4 hours	50-60 minutes
Sag/Slump, ASTM D2202	0.1" max	N.A.
Storage Temperature	<80F (27C)	<80F (27C)
Installation Temperature	-35°F to 140°F (-37°C to 60°C)	-35°F to 140°F (-37°C to 60°C)
Shelf Life	18 mos	18 mos
Storage Warranty Period*	12 mos	12 mos
Weight Per Gallon	11.6 lbs/gal	11.5 lbs/gal
Viscosity	1,200,000 cps	25,000 cps

Table A: Typical Properties – Cured		
Property	SIL300 (Non-Sag)	SIL300SL (Self-Leveling)
Color	Concrete (limestone)	Concrete (limestone)
Hardness, Durometer (Type A Indentor), ASTM D2240	24	26
Ultimate Tensile Strength, ASTM D412	341 psi (2.35 MPa)	110 psi (0.76 MPa)
Ultimate Elongation, ASTM D412	715%	600%
Tensile at 100% Elongation, ASTM D412	73.2 psi (0.50 MPa)	60 psi (0.41 MPa)
Peel Strength (21 day cure @ 77°F/50 RH), ASTM C794	56.6 pli	12 pli
Movement Capability		
ASTM C719	± 50%	± 50%
ASTM E1399	± 35%	± 15%
In Service Temperature	-35°F (-37°C) to 350°F (177°C)	-35°F (-37°C) to 300°F (149°C)
Weathering & U.V. Resistance	Excellent	Excellent
Flame Spread Index, ASTM E84 or UL723	5	5
Smoke Developed Index, ASTM E84 or UL723	45	45
STC Rating	61	61

*From date of shipment if stored in original unopened container at 80°F (27°C).



INSTALLATION INSTRUCTIONS

SpecSeal® Series SIL Silicone Firestop Sealant is approved for a variety of through-penetration firestop systems and joint applications. Some typical installations have been illustrated here to assist in the selection of the proper installation method. Space limitations preclude highly detailed information pertaining to individual application systems. Please consult the STI Product and Application Guide, as well as the UL Fire Resistance Directory for additional information.

Preparation: All surfaces to receive SpecSeal® Series SIL Silicone Firestop Sealant must be clean, sound, dry, frost-free, and free of bond-breaking contaminants and loose material. Clean as necessary by wire brush, mechanical abrading, grinding, blast cleaning, or wiping with a suitable solvent to remove any contaminants. Mask all areas where adhesion is undesirable. Do not apply to wet or frost covered surfaces.

Forming: Some installations may require forming as either an integral part of the system or as an option to facilitate installation. In systems where forming is required, mineral wool batt insulation (minimum 4 lb./cu. ft. or 64 kg/m3 density) is recommended for use in through-penetrations and joints. Where forming materials are required, cut oversized to allow for tight packing. Some individual joint systems may specify a minimum compression factor to allow designed amount of movement. Position forming material as required for the proper depth of fill material.

Fill Material: SpecSeal® Series SIL300 Silicone Firestop Sealant may be installed by caulking using a standard caulking gun or from bulk containers using a bulk loading caulk gun, or by manually troweling using a mason's trowel or putty knife. SIL300SL may be installed by pouring the sealant into the opening and allowing it to find level. If the sealant tends to pull back from a surface, clean the surfaces using the methods described above and reapply. Install sealant to required depth. For SIL300, work sealant into all areas with a tooling knife exercising care to eliminate voids or seams. In gypsum wall board penetrations, crown sealant a minimum of 1/4" (7 mm) from penetrant to wallboard surface at a point approx. 1/2" (13 mm) or more from opening. For applications involving cable bundles, spread cables sufficiently to ensure that sealant completely seals all cables and totally fills all voids to the required depth. Exercise care when using SIL300SL that packing material has been installed tightly into opening to prevent leakage of fill material.

Priming: SpecSeal® Series SIL Silicone Firestop Sealants have primerless adhesion to many construction materials including untreated or uncoated concrete. Jobsite trial applications are recommended if contact surfaces are in any way questionable. Application of a suitable primer may remedy adhesion difficulties for questionable concrete surfaces. Contact the factory for primer recommendations.

Masking: The use of masking tape is recommended where appropriate to insure a neat job and to protect adjoining surfaces. Do not allow masking tape to touch clean surfaces to which the silicone sealant is to adhere. Masking tape should be removed immediately after the finish tooling of the SpecSeal® Series SIL Silicone Firestop Sealant.

Smoke Sealing: SpecSeal® Series SIL Silicone Firestop Sealants make an excellent smoke seal. Apply to gaps and seams to prevent the passage of smoke. Some SpecSeal Firestop Collar designs utilize SpecSeal® Series SIL Silicone Firestop Sealants as the smoke seal. Please consult the STI Product and Application Guide, as well as the UL Fire Resistance Directory for additional information.

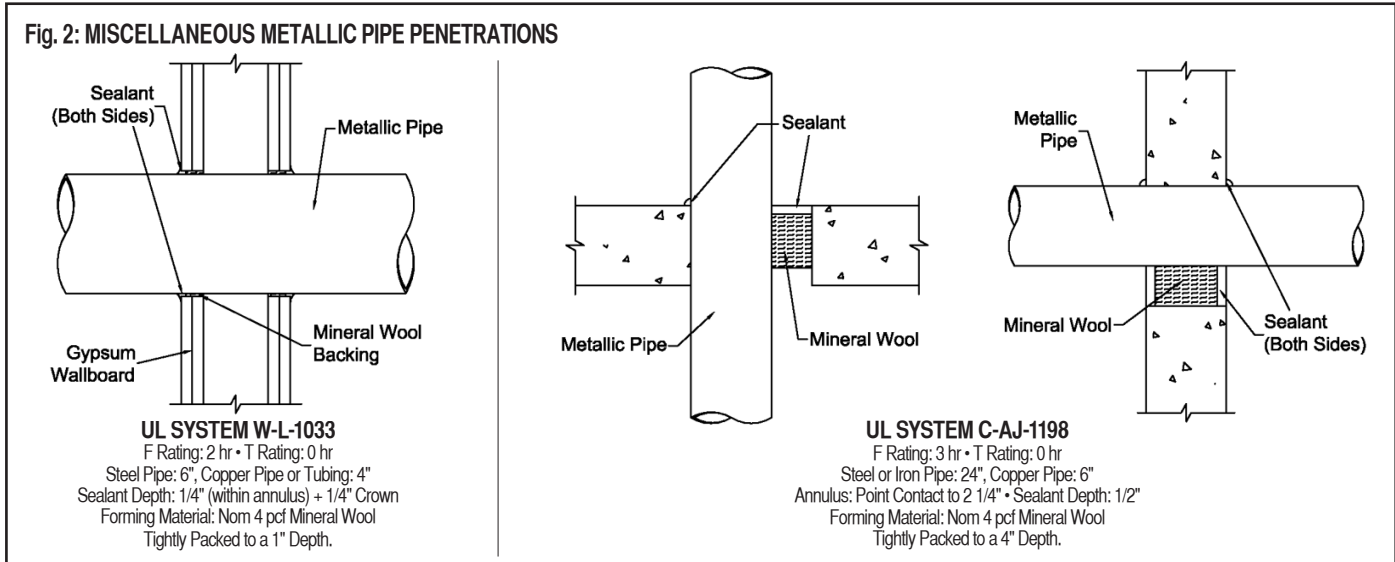
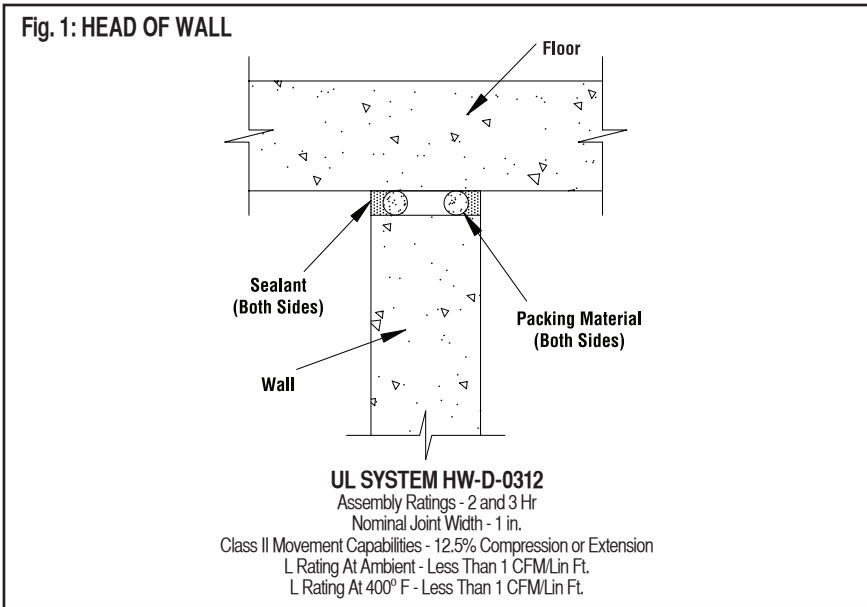

Table A: SEALANT REQUIREMENTS IN CUBIC INCHES PER 1/4 INCH OF INSTALLED DEPTH*

PIPE SIZE		Diameter of Opening - in. (mm)											
Trade Size in. (mm)	Pipe O.D. in. (mm)	1.5 (38)	2.0 (51)	3.0 (76)	4.0 (102)	5.0 (127)	6.0 (152)	7.0 (178)	8.0 (203)	10 (254)	12 (305)	14 (356)	26 (660)
0.5 (13)	0.840 (21)	0.3 (4.9)	0.6 (9.8)	1.6 (26.2)	3.0 (49.2)	4.8 (78.7)	6.9 (113.0)	9.5 (155.7)	12.4 (203.2)	19.5 (319.5)	28.1 (460.5)	38.3 (627.6)	132.6 (2173)
1.0 (25)	1.315 (33)	0.1 (1.6)	0.4 (6.6)	1.4 (22.9)	2.8 (45.9)	4.6 (75.4)	6.7 (109.8)	9.3 (152.4)	12.2 (200.0)	19.3 (316.3)	27.9 (457.2)	38.1 (624.3)	132.4 (2170)
1.5 (38)	1.900 (48)			1.1 (18.0)	2.4 (39.3)	4.2 (68.8)	6.4 (104.9)	8.9 (145.8)	11.9 (195.0)	18.9 (309.0)	27.6 (452.3)	37.8 (619.4)	132.0 (2163)
2.0 (51)	2.375 (60)			0.7 (11.5)	2.0 (32.8)	3.8 (62.3)	6.0 (98.3)	8.5 (139.2)	11.5 (188.4)	18.5 (309.7)	27.2 (445.7)	37.4 (568.6)	131.6 (2157)
2.5 (64)	2.875 (73)			0.1 (1.6)	1.5 (24.6)	3.3 (54.1)	5.4 (88.4)	8.0 (131.1)	10.9 (178.6)	18.0 (295.0)	26.7 (437.5)	36.9 (604.7)	131.1 (2148)
3.0 (76)	3.500 (79)				0.7 (11.5)	2.5 (41.0)	4.7 (77.0)	7.2 (118.0)	10.2 (167.1)	17.2 (281.9)	25.9 (424.4)	36.1 (591.6)	130.3 (2135)
3.5 (89)	4.000 (102)					1.8 (29.5)	3.9 (63.9)	6.5 (106.5)	9.4 (154.0)	16.5 (270.4)	25.1 (411.3)	35.3 (578.5)	129.6 (2124)
4.0 (102)	4.500 (114)					0.8 (13.1)	3.0 (49.2)	5.6 (91.8)	8.5 (139.3)	15.6 (255.6)	24.2 (396.6)	34.4 (563.7)	128.7 (2109)
6.0 (152)	6.625 (168)							1.1 (18.0)	4.0 (65.5)	11.1 (181.9)	19.7 (322.8)	29.9 (490.0)	124.2 (2035)
8.0 (203)	8.625 (219)									4.9 (80.3)	13.6 (222.9)	23.8 (390.0)	118.0 (1934)
10.0 (254)	10.750 (273)										5.6 (91.8)	15.8 (259.0)	110.0 (1803)
12.0 (305)	12.750 (324)											6.6 (108.1)	100.8 (1652)
24.0 (610)	24.000 (610)												19.6 (321.2)

*Different Sealant Depth?
 1/2" (12.7) Multiply by 2
 5/8" (15.9) Multiply by 2.5
 1" (25.4) Multiply by 4
 1-1/4" (31.8) Multiply by 5

Table B: PRODUCT ESTIMATION INFORMATION (Construction Joints)

JOINT WIDTH in. (mm)	PER 1/4" INSTALLED DEPTH			PER 1/2" INSTALLED DEPTH			PER 1" INSTALLED DEPTH		
	CU IN/FT (cm ² /m)	FT/GAL (m/L)	GAL/100 FT (L/100 m)	CU IN/FT (cm ² /m)	FT/GAL (m/L)	GAL/100 FT (L/100 m)	CU IN/FT (cm ² /m)	FT/GAL (m/L)	GAL/100 FT (L/100 m)
0.5 (13)	1.5 (79)	154.0 (12.4)	0.65 (8.1)	3.0 (158)	77.0 (6.2)	1.3 (16.4)	6.0 (317)	38.5 (3.1)	2.6 (32.2)
0.75 (19)	2.3 (121)	102.0 (8.2)	0.95 (11.8)	4.5 (238)	51.3 (4.2)	1.9 (23.6)	9.0 (476)	25.7 (2.1)	3.9 (48.4)
1.0 (25)	3.0 (158)	77.0 (6.2)	1.3 (16.4)	6.0 (317)	38.5 (3.1)	2.6 (32.2)	12.0 (634)	19.3 (1.6)	5.2 (65.5)
1.5 (38)	4.5 (238)	51.0 (4.1)	2.0 (24.8)	9.0 (476)	25.7 (2.1)	3.9 (48.4)	18.0 (951)	12.8 (1.0)	7.8 (96.7)
2.0 (51)	6.0 (317)	38.0 (3.1)	2.6 (32.2)	12.0 (634)	19.3 (1.6)	5.2 (64.5)	24.0 (1269)	9.6 (0.8)	10.4 (129.0)
2.5 (64)	8.0 (423)	31.0 (2.5)	3.3 (40.9)	15.0 (793)	15.4 (1.2)	6.5 (80.6)	30.0 (1586)	7.7 (0.6)	13.0 (161.2)
3.0 (76)	9.0 (476)	25.0 (2.0)	3.9 (48.4)	18.0 (951)	12.8 (1.0)	7.8 (96.7)	36.0 (1903)	6.4 (0.5)	15.6 (193.4)
3.5 (89)	11.0 (581)	22.0 (1.8)	4.6 (57.0)	21.0 (1110)	11.0 (0.9)	9.1 (112.8)	42.0 (2220)	5.5 (.045)	18.2 (225.7)
4.0 (102)	12.0 (634)	19.0 (1.5)	5.2 (64.5)	24.0 (1269)	9.6 (0.8)	10.4 (129.0)	48.0 (2537)	4.8 (0.39)	20.8 (257.9)
5.0 (127)	15.0 (793)	15.0 (1.2)	6.5 (80.6)	30.0 (1586)	7.7 (0.6)	13.0 (161.2)	60.0 (3172)	3.9 (0.32)	26.0 (322.4)
6.0 (152)	18.0 (951)	12.0 (1.0)	7.8 (96.7)	36.0 (1903)	6.4 (0.5)	15.6 (193.4)	72.0 (3806)	3.2 (0.26)	31.2 (386.9)

TABLE IS FOR ESTIMATING PURPOSES ONLY

MAINTENANCE

Inspection: Installations should be inspected periodically for subsequent damage. Any damage should be repaired using SpecSeal® products per the original approved design. Cut away damaged material and reapply sealant as required. NOTE: New penetrants of a different nature than the original design may require a totally new firestop design or extensive modifications to the existing design. Reseal all openings as per the requirements of the modified design.

TECHNICAL SERVICE

Specified Technologies Inc. provides toll free technical support to assist in product selection and appropriate installation design. UL Systems, Material Safety Data Sheets and other technical information is available at the Technical Library at www.stifirestop.com.

PRECAUTIONARY INFORMATION:

Avoid contact with eyes. Uncured product may irritate eyes on contact. Use only in well ventilated areas. To clean areas of skin contact, wipe off uncured material with a dry cloth or paper towel prior to washing. Waterless hand cleaners are particularly effective while sealant is uncured. Consult Material Safety Data Sheet for additional information on the safe handling and disposal of this material.

AVAILABILITY

SpecSeal® Series SSM Firestop Mortar is available from authorized STI distributors worldwide. Visit www.stifirestop.com or call US Toll Free: 800.992.1180 or Outside US: +1 908 526 8000 for information concerning where to purchase these and other STI products.



Fig. 3: TYPICAL JOINT INSTALLATION METHODS

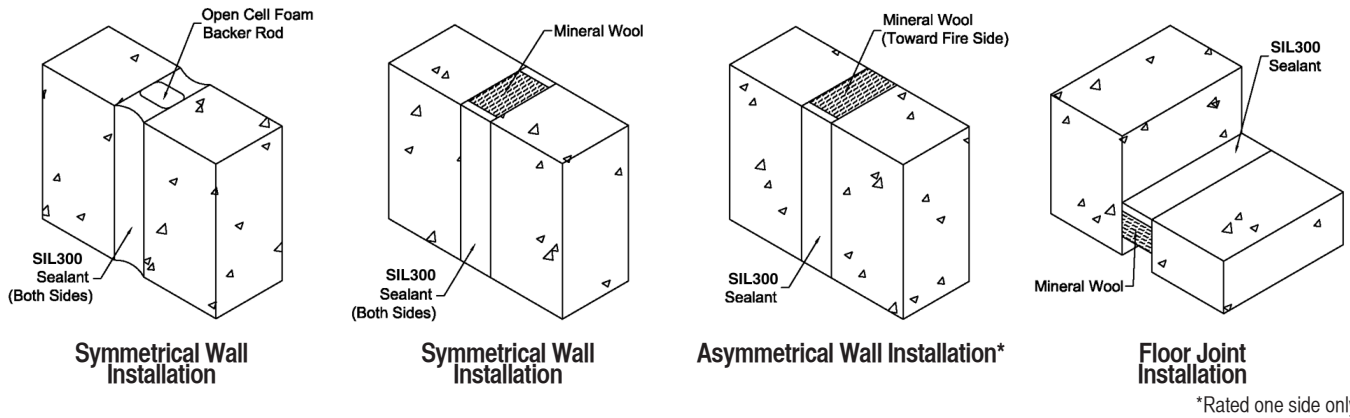

ORDERING INFORMATION

CAT. NO.	DESCRIPTION
SIL300	10.1 oz Tube (300 ml) 18.2 cu. in.
SIL305	4.5 Gal. Pail (17.0 liters) 1,037 cu. in.
SIL320	20 oz. Sausage Tube (592 ml) 36 cu. in
SIL305SL	Self-leveling 4.5 Gal. Pail (17.0 liters) 1,037 cu. in.
SIL320SL	Self-leveling 20 oz. Sausage Tube (592 ml) 36 cu. in

IMPORTANT NOTICE: All statements, technical information, and recommendations contained herein are based upon testing believed to be reliable, but the accuracy and completeness thereof is not guaranteed.

LIMITED WARRANTY: Specified Technologies Inc.(STI) manufactures its goods in a manner to be free of defects. Should any defect occur in its goods (within one year), Specified Technologies Inc., upon prompt notification, will at its option, exchange or repair the goods or refund the purchase price for any product proven to be defective when installed in accordance with STI's published recommendations and in applications considered by STI as suitable for this product.

LIMITATIONS AND EXCLUSIONS: THIS WARRANTY IS IN LIEU OF ALL OTHER REPRESENTATIONS AND EXPRESSED OR IMPLIED WARRANTIES (including the implied warranties of merchantability or fitness for use) AND UNDER NO CIRCUMSTANCES SHALL SPECIFIED TECHNOLOGIES INC. BE LIABLE FOR ANY INCIDENTAL OR CONSEQUENTIAL PROPERTY DAMAGES OR LOSSES.

MADE IN USA – COPYRIGHT © 2011 SPECIFIED TECHNOLOGIES INC.

<p>CLASSIFIED UL US</p>	<p>FILL, VOID OR CAVITY MATERIALS FOR USE IN JOINT SYSTEMS AND THROUGH-PENETRATION FIRESTOP SYSTEMS. SEE UL FIRE RESISTANCE DIRECTORY 3L73</p>	<p>FM APPROVED</p>	<p>1408/11</p>	<p>FBC SYSTEM COMPATIBLE</p>	<p>FBC™ System Compatible indicates that this product has been tested, and is monitored on an ongoing basis, to assure its chemical compatibility with FlowGuard Gold®, BlazeMaster® and Corzan® pipe and fittings. FBC, FlowGuard Gold, BlazeMaster and Corzan are licensed trademarks of The Lubrizol Corporation.</p>
---------------------------------	--	------------------------	----------------	----------------------------------	--

STI is a member of the following organizations:



Specified Technologies Inc. • Somerville, NJ 08876 USA • US Toll Free: (800) 992-1180 • Outside US: + 1 908 526 8000 • www.stifirestop.com

